

COLLECTION  
LUMINAIRES  
2022

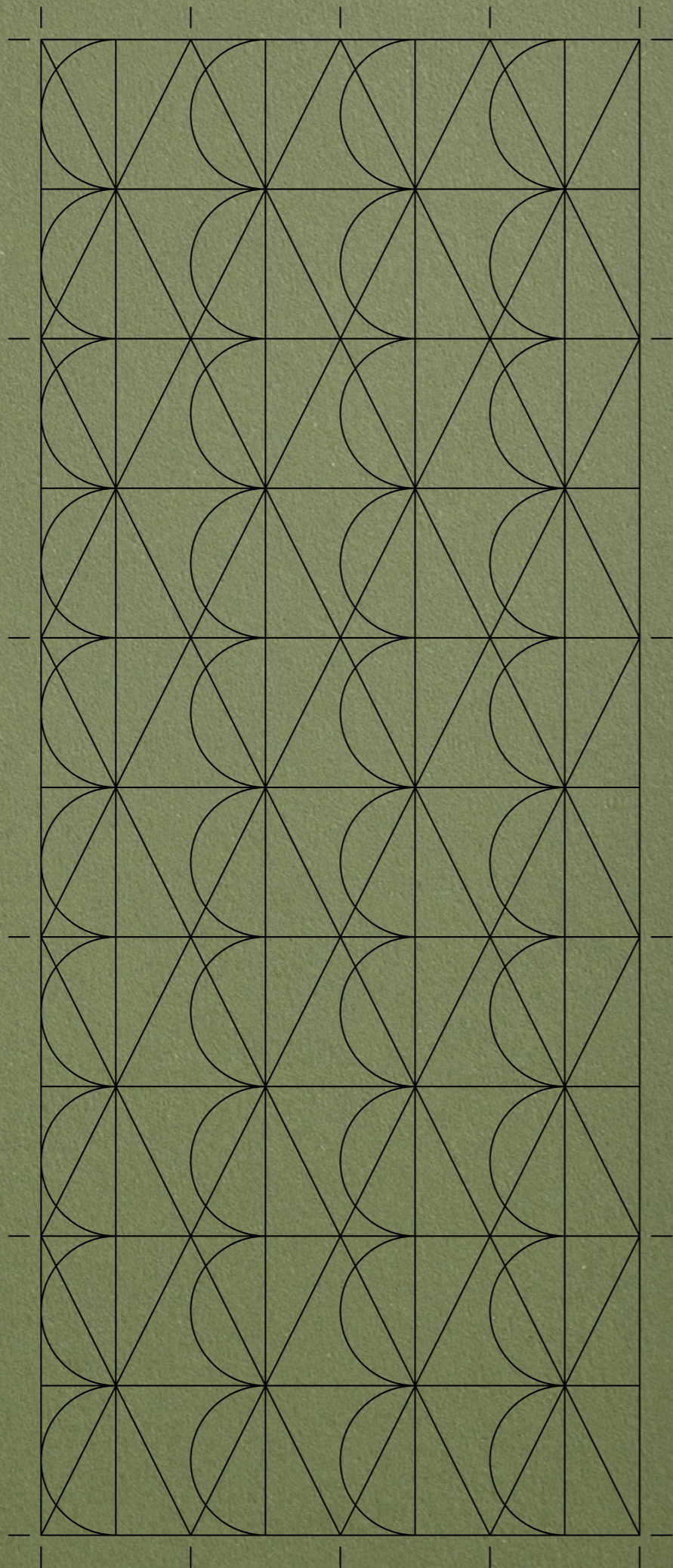



#### UNE ENTREPRISE FAMILIALE 100% FRANÇAISE

Il y a bientôt trente ans, Éric Baron reprenait le flambeau de l'entreprise familiale CVL, fondée par son père Henri en 1960. Le nouveau président a très vite impulsé un virage vers le design et un parti pris contemporain. La collection de luminaires traditionnels en fer forgé et céramique a progressivement laissé place à une gamme résolument moderne, aujourd'hui réalisée en laiton massif. La qualité du matériau et la perfection des lignes sont les qualités premières qui inspirent les clients de CVL.

Forte de six décennies d'expérience, son équipe de trente-cinq salariés s'applique au quotidien à préserver et enrichir ces savoir-faire uniques dans la fabrication de luminaires en laiton, au sein d'une unité de production installée près d'Angers, dans la région Pays de la Loire...

Les artisans de CVL sont tous des hommes et femmes de l'art, passionnés par leur métier. Ils fabriquent l'intégralité des collections à la main, dans la maîtrise de gestes minutieux, au sein d'ateliers à la frontière de l'orfèvrerie et de l'industrie.

#### A 100% FRENCH FAMILY COMPANY

Nearly 30 years ago, Éric Baron took over the family business CVL founded by his father Henri in 1960. The new president very quickly initiated a shift towards design and a contemporary bias. The collection of traditional wrought iron and ceramic lights has gradually given way to a resolutely modern range, now made of solid brass. The quality of the material and the perfection of the lines are the primary qualities that inspire CVL's clients.

With six decades of experience, its team of thirty-five employees works daily to preserve and enrich their unique know-hows in the manufacture of brass lighting, within a production unit located near Angers, in the region of the Loire Valley...

The craftsmen of CVL are all men and women of art, passionate about their profession. They manufacture all of the collections by hand, mastering meticulous techniques, in workshops on the border line between goldsmith and industry.



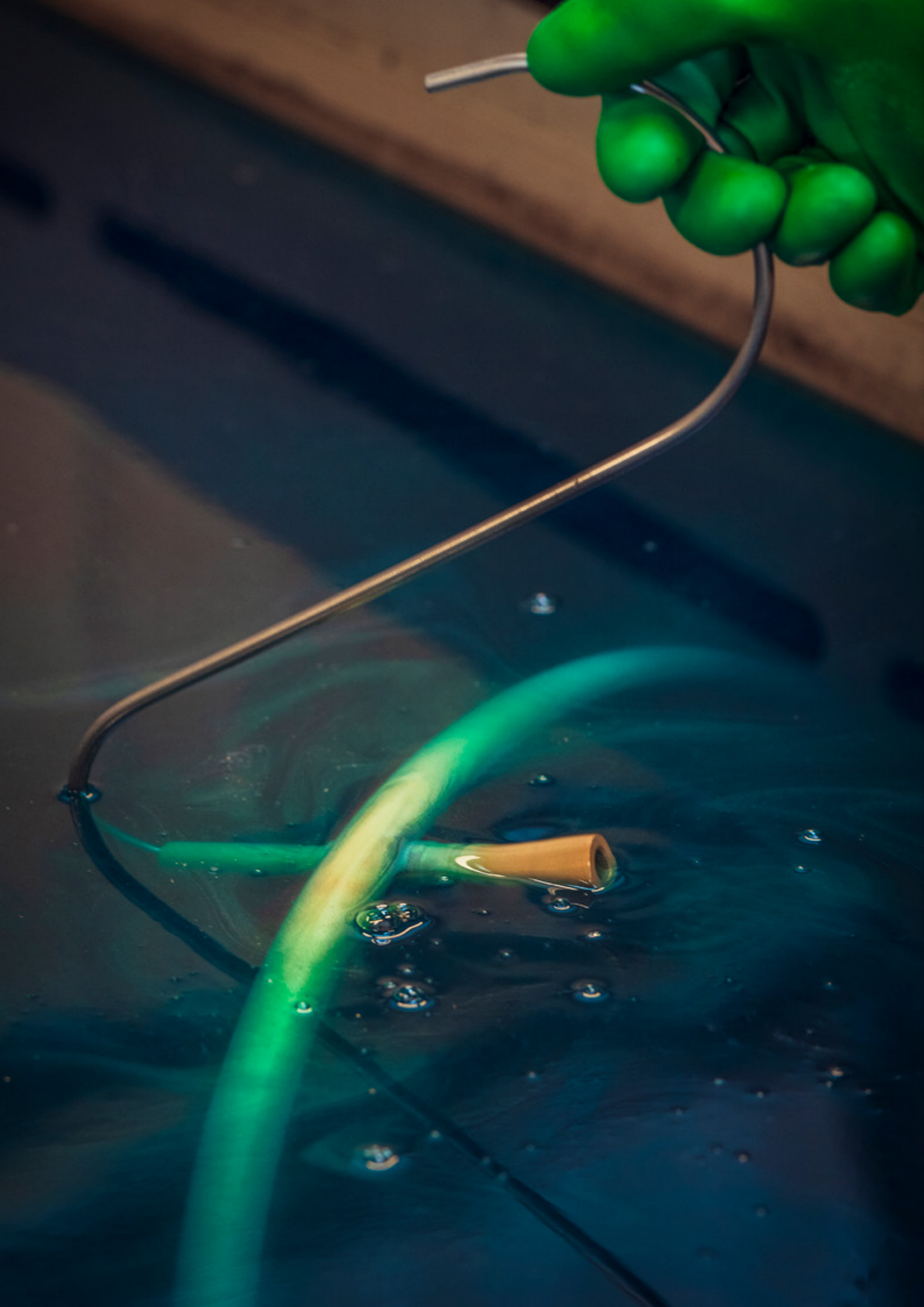

#### **ESPRIT D'ÉQUIPE ET FAMILLE DE CRÉATEURS**

Designer intégrée chez CVL, Émilie Cathelineau est chargée de développer les nouveaux produits et d'animer la cellule de création et le bureau d'études. Elle planche également sur les projets sur mesure : ce service est unanimement apprécié par les prescripteurs dont les requêtes pointues requièrent une expertise poussée. Sans renier son savoir-faire ancestral, CVL a su s'adapter aux nouvelles technologies et s'est dotée de logiciels de création performants, permettant la réalisation de fichiers et rendus 3D indispensables à ses clients.

Depuis plusieurs années, l'entreprise a su s'ouvrir au regard et à l'inventivité de designers indépendants tels que Hervé Langlais, Pauline Deltour ou Sylvain Willenz. En 2018, elle a démarré une collaboration avec Léa Padovani et Sébastien Kiffer du studio POOL. Elle a confié au duo de créateurs parisiens la réalisation de son nouveau graphisme ainsi que la direction artistique de ses collections. Cette fructueuse collaboration est le gage d'une image de marque modernisée, mais aussi de nouvelles collections, toujours en harmonie avec l'esprit CVL.

#### **TEAM SPIRIT AND FAMILY OF DESIGNERS**

Integrated designer at CVL, Émilie Cathelineau is responsible for developing new products and responsible for leading the creation unit and the design office. She also works on bespoke projects : this service is unanimously appreciated by specifiers whose specific requests require in-depth expertise. Without denying its ancestral know-how, CVL has been able to adapt to new technologies and is equipped with high-performance creation software, allowing the creation of 3D files and renderings essential to its customers.

For several years, the company has been opening to the eyes and inventiveness of independent designers such as Hervé Langlais, Pauline Deltour or Sylvain Willenz. In 2018, the company started a collaboration with Léa Padovani and Sébastien Kiffer from the POOL studio. CVL entrusted the duo of Parisian designers with the realization of its new graphics as well as the artistic direction of its collections. This fruitful collaboration is the pledge of a modernized brand image, but also of new collections, always in harmony with the CVL.

#### **UNE DISTRIBUTION INTERNATIONALE ET DES PROJETS À TRAVERS LE MONDE**

Fort d'un solide réseau de partenaires, CVL est représentée sur les cinq continents. L'entreprise familiale expose régulièrement ses créations dans les salons les plus prestigieux : Euroluce à Milan, ICFF à New York, Maison et Objet, Architect@Work et Equip'Hotel à Paris... Ses clients, architectes et décorateurs, plébiscitent ses luminaires dans le cadre de leurs projets, résidentiels comme hôteliers. CVL peut s'enorgueillir de sa présence dans des aménagements privés de standing autant que des rénovations hôtelières de prestige et des boutiques de luxe : Waldorf Astoria, Marriott, Four Seasons, Crowne Plaza, Cartier, Boucheron, Harrods... pour n'en citer que quelques-uns.

#### **INTERNATIONAL DISTRIBUTION AND PROJECTS AROUND THE WORLD**

With a strong network of partners, CVL is represented on five continents. The family business regularly exhibits its creations at the most prestigious fairs : Euroluce in Milan, ICFF in New York, Maison et Objet, Architect@Work and Equip'Hotel in Paris... Its clients, architects and decorators, praise its lighting as part of their projects, both residential and commercial. CVL can be proud of its presence in luxury private facilities as well as prestigious hotel renovations and luxury boutiques : Waldorf Astoria, Marriott, Four Seasons, Crowne Plaza, Cartier, Boucheron, Harrods... to only quote a few.

## UN SAVOIR-FAIRE RECONNU ET RECHERCHÉ

Les architectes d'intérieur et décorateurs à la recherche d'un savoir-faire artisanal de haut niveau sont nombreux à confier la réalisation de leurs pièces à CVL. L'entreprise est en permanence à l'écoute de ses clients et de leurs besoins. Elle a développé un regard pointu, tourné vers l'architecture, sans compromis ni concession sur la technicité et la performance. La maîtrise de toutes les étapes de production – dès le prototypage réalisé en interne – et des technologies de l'éclairage, permettent à CVL d'offrir flexibilité et rapidité d'exécution, deux vertus indispensables pour ses clients. Pièce unique ou série, cette PME se remet constamment en question, s'adaptant en permanence par exemple à l'évolution des technologies LED, et développant des luminaires complexes qui répondent à des normes internationales toujours plus exigeantes. La certification « UL » des produits pour le marché nord-américain, et le développement d'une collection destinée à la salle de bain sont de parfaites illustrations de cette philosophie d'amélioration constante. Pour une qualité irréprochable, chaque produit est vérifié et testé avant emballage.

## A RECOGNIZED AND SOUGHT-AFTER KNOW-HOW

Many interior architects and decorators looking for high-level craftsmanship entrust the creation of their pieces to CVL. The company is constantly attentive to its customers and their needs. She has developed a sharp eye, turned towards architecture, without compromise or concession on technicality and performance. The control of all stages of production, from prototyping carried out internally and lighting technologies, allow CVL to offer flexibility and speed of execution, two essential virtues for its customers. One-offs or series, this SMB is always questioning itself, constantly adapting, for example, to the evolution of LED technologies and developing complex luminaires that meet ever more demanding international standards. The "UL" certification of products for the North American market, and the development of a bathroom collection, are perfect illustrations of this philosophy of constant improvement. For impeccable quality, each product is checked and tested before packaging.

## QUALITÉ ET ENGAGEMENT DURABLE

CVL s'inscrit par ailleurs dans une démarche vertueuse en matière de développement durable. L'unité de production près d'Angers bénéficie ainsi d'une installation répondant à toutes les normes en vigueur. Une station de recyclage interne assure un fonctionnement « rejet zéro » : les bains de traitement et les eaux de rinçage sont réutilisés pour éviter tout déversement dans le milieu naturel. La cellule de développement est elle aussi en veille permanente sur l'évolution des technologies et des normes. Elle s'appuie sur le laboratoire de test interne pour s'assurer de la conformité et de la pérennité de ses créations.

## QUALITY AND SUSTAINABLE COMMITMENT

CVL is also part of a virtuous approach to sustainable development. The production unit near Angers thus benefits from an installation that meets all the standards in force. An internal recycling station ensures a "zero rejection" operation: the treatment baths and the rinsing water are reused to prevent any spillage into the natural environment. The development unit is also constantly on the lookout for changes in technologies and standards and relies on the internal test laboratory to ensure the compliance and sustainability of its creations.





« L'architecture est le jeu savant, correct et magnifique des formes assemblées dans la lumière. » (Le Corbusier)

Le Corbusier defined architecture as "the masterly, correct & magnificent interplay of masses brought together in light".

À travers ses collections, CVL s'attache à créer une ambiance lumineuse qui souligne les formes et les espaces. Ses produits sont agréables à l'œil, allumés comme éteints. Les matériaux sont l'incarnation de leur philosophie design. L'identité de CVL s'affirme à travers un catalogue sans fioritures qui regorge de modèles au dessin subtil, fabriqués dans les règles de l'art et intemporels...

Through its collections, CVL strives to create a light atmosphere that emphasizes shapes and spaces. Its products are pleasing to the eye, both on or off. The materials are the embodiment of their design philosophy. The identity of CVL is affirmed through an unadorned catalog full of models with subtle designs, crafted in the rules of the art and timeless...





## DESIGNERS



### ÉMILIE CATHELINEAU

Lorsque qu'Émilie Cathelineau rejoint CVL en tant que designer intégrée en 2003, l'entreprise n'a pas encore de bureau de création. Sa mission : faire évoluer la gamme encore très classique, mais reconnue pour la qualité de ses finitions. Spécialiste du luminaire, elle est la personne de référence pour le développement de produits et fait le lien avec les autres designers. Aujourd'hui, Émilie a plus d'une dizaine de collections à son actif. Déclinées sous toutes les formes de luminaires, elles empruntent leur style autant aux mouvements Art déco qu'au design contemporain.

When Émilie Cathelineau became part of CVL as a designer back in 2003 the company did not yet have a design studio. Her mission was to develop the existing classic range which was known for its quality and various finishes. As an expert in lighting, she is the person in charge for the development of the products and goes over changes and novelties with the other designers. At present, Émilie has designed over ten collections. Made up of all sorts and forms of lights, her collections are inspired from other Art Déco styles to contemporary designs.



### PAULINE DELTOUR

Après Olivier de Serres et l'École Nationale Supérieure des Arts Décoratifs de Paris, Pauline Deltour part, durant trois ans, assister à Munich le designer allemand Konstantin Grcic. Elle apprend à ses côtés son métier, envisage de nouvelles méthodes de travail et approfondit son vocabulaire stylistique. En 2011, armée d'une expérience solide, Pauline Deltour revient à Paris et monte son entreprise de design d'objets. Elle collabore également à des projets de scénographie en architecture d'intérieur. En 2017, elle rejoint l'équipe de créateurs de CVL et dessine la collection Signal.

After studying at Olivier de Serres and Paris's famous École nationale supérieure des arts décoratifs, Pauline Deltour assisted the German designer Konstantin Grcic during three years. During her time with him she learnt more about her job, considered new working skills and gained further stylistic vocabulary. In 2011 Pauline Deltour returned to Paris, with even more experience, and set up her own company of designing objects. She also collaborated on stage design projects in interior architecture. In 2017 she joined CVL's designer team and created the Signal collection.



### HERVÉ LANGLAIS

Architecte de formation, Hervé Langlais collabore de nombreuses années avec Paul Andreu, spécialiste français des constructions aéroportuaires, et y dessine le Grand Théâtre National de Chine à Pékin ou encore l'Oriental Art Center à Shanghai. Vingt ans plus tard, il retrouve ses premiers amours et développe une activité de designer produit. Cet ancien dessinateur de structure accorde une attention particulière aux détails, aux formes épurées et à la rareté des matériaux. Premier designer indépendant à officier pour CVL.

Trained as an architect, Hervé Langlais collaborated for many years with Paul Andreu, a specialist in airport constructions, and together designed the National Centre for the Performing Arts in Beijing in China and even the Shanghai Oriental Art Center. Twenty years later, he started again what he loved doing and developed a product designer activity. This former building designer grants specific importance to each detail, refined form and to the rarity of materials. Hervé is the first independent designer to become part of the CVL team.



### POOL

Le studio de création parisien, fondé en 2011 par Léa Padovani et Sébastien Kieffer, intervient autant dans les champs du mobilier, de l'environnement que de l'architecture d'intérieur. Collections signées ou collaborations avec d'autres ateliers et manufactures, le duo POOL réfléchit ses créations dans leur contexte global. La composition géométrique, où formes et couleurs agencent des volumes radicaux, se décline comme une véritable marque de fabrique du tandem transdisciplinaire. Passionnés par les savoir-faire et les rapports humains, ils interviennent régulièrement en tant que directeurs artistiques auprès d'artisans d'art. Tâche que CVL leur a confiée depuis 2017.

The Parisian design studio, founded in 2011 by Léa Padovani and Sébastien Kieffer, intervenes in as many domains as furniture, environment, and interior architecture. The duo POOL studies its creations in a global context, either when signing their own collections or collaborating with other workshops and manufacturers. The geographical composition where forms and colors end up as radical volumes, is the signature of Pool transdisciplinary tandem. Passionate by the know-how of craftsmen and art manufacturers and by human connections, they often act as artistic directors, a role they have had since 2017 for CVL.



### SYLVAIN WILLENZ

Né à Bruxelles en 1978, Sylvain Willenz a vécu aux Etats-Unis, en Belgique et en Grande Bretagne. Diplômé du Royal College of Art de Londres en 2003, Willenz ouvre un an plus tard son bureau de design à Bruxelles. Willenz fut nommé designer Belge de l'année en 2009. Connue pour son esthétique simple et graphique, Willenz est fasciné par la l'industrie et l'artisanat, la production et les matériaux. Au cours des années, il a développé un style singulier, une ligne claire, insufflant ainsi à ses créations une élégance unique, classique et si reconnaissable aujourd'hui.

Born in Brussels in 1978, Sylvain Willenz has lived consecutively in the US, Belgium and in the UK. Sylvain studied MA Design Products at the Royal College of Art in London, graduating in 2003. In 2004, he opened his Design Office, based in Brussels, Belgium. Considered as one of the most influential Belgian creatives, Sylvain was named Belgian Designer of the Year in 2009. Renown for his strong yet simple graphic aesthetic, Sylvain is fascinated by production, manufacturing and pays great attention to detail. Over the years, Sylvain developed a singular style of ligne claire, which instills his simple, elegant and graphic designs, so recognisable and unique today.



## INDEX

### A

- 20 **Arborescence** Suspensions – Pendants
- 23 **Arborescence** Appliques – Wall lights
- 26 **Arborescence** Lampadaires – Floor lamps
- 23 **Arborescence** Lampes de table – Table lamps
- 28 **Atmos** Appliques – Wall lights

### C

- 36 **Calé(e)** Suspensions – Pendants
- 46 **Calé(e)** Appliques – Wall lights
- 46 **Calé(e)** Spots
- 50 **Calé(e)** Lampadaires – Floor lamps
- 48 **Calé(e)** Lampes de table – Table lamps
- 52 **Cercle & trait** Suspension – Pendant
- 58 **Constellation** Applique – Wall light
- 62 **Cornet** Suspension – Pendant
- 64 **Cornet** Appliques – Wall lights
- 68 **Couture** Lampe de table – Table lamp
- 72 **Curve** Lampadaire – Floor lamp
- 74 **Curve** Lampe de table – Table lamp

### E

- 76 **Earth** Appliques – Wall lights
- 82 **Éclipse** Applique – Wall light
- 86 **Ellis** Lampadaire – Floor lamp
- 88 **Ellis** Lampe de table – Table lamp

### F

- 90 **Fléa** Suspension – Pendant
- 92 **Fléa** Applique – Wall light

### G

- 96 **Gamma** Suspension – Pendant
- 99 **Gamma** Applique – Wall light

### J

- 104 **Janed** Applique – Wall light
- 110 **Janed** Lampe de table – Table lamp

### L

- 122 **Link** Suspension – Pendant
- 112 **Link** Appliques – Wall lights
- 115 **Link** Liseuses – Reading wall lights
- 121 **Link** Lampadaire – Floor lamp
- 121 **Link** Lampe de table – Table lamp
- 124 **Louis** Suspensions – Pendants

### N

- 130 **Nacho** Suspensions – Pendants

### R

- 134 **Ring** Suspension – Pendant

### S

- 138 **Saturne** Suspensions – Pendants
- 142 **Signal** Suspensions – Pendants
- 150 **Signal** Appliques – Wall lights
- 152 **Signal** Lampadaires – Floor lamps
- 156 **Solitaire** Lampadaires – Floor lamps
- 160 **Storm** Suspension – Pendant
- 163 **Storm** Applique – Wall light
- 163 **Storm** Lampadaire – Floor lamp
- 162 **Storm** Lampes de table – Table lamps
- 166 **Strate** Appliques – Wall lights

### T

- 174 **Tetra** Applique – Wall light

### U

- 180 **Upper** Lampadaire – Floor lamp

### W

- 188 **Wonder** Applique – Wall light
- 184 **Wonder** Lampes de table – Table lamps

## SALLE DE BAIN BATHROOM

- 192 **IP Backstage** Appliques – Wall lights
- 198 **IP Calé(e)** Appliques – Wall lights
- 200 **IP Cornet** Appliques – Wall lights
- 204 **IP Gamma** Appliques – Wall lights

- 206 **IP Link** Appliques – Wall lights
- 210 **IP Metrop** Appliques – Wall lights
- 214 **IP Storm** Appliques – Wall lights

## 222 Finitions / Finishes

SUSPENSIONS  
PENDANT LIGHTS

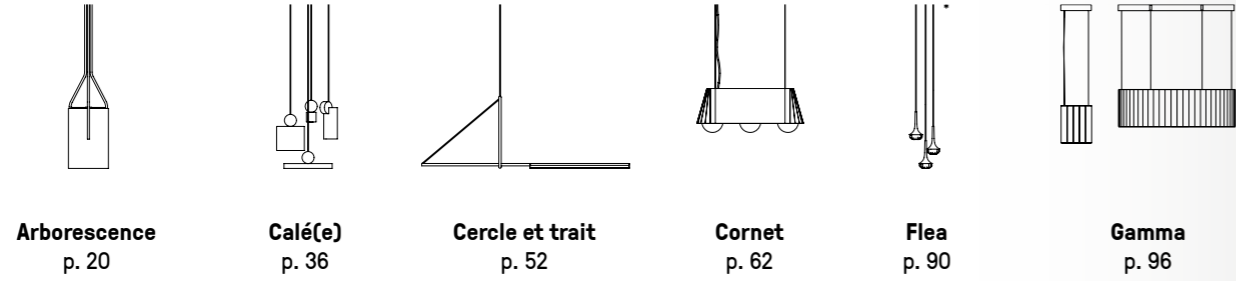

**Arborescence** p. 20  
**Calé(e)** p. 36  
**Cercle et trait** p. 52  
**Cornet** p. 62  
**Flea** p. 90  
**Gamma** p. 96

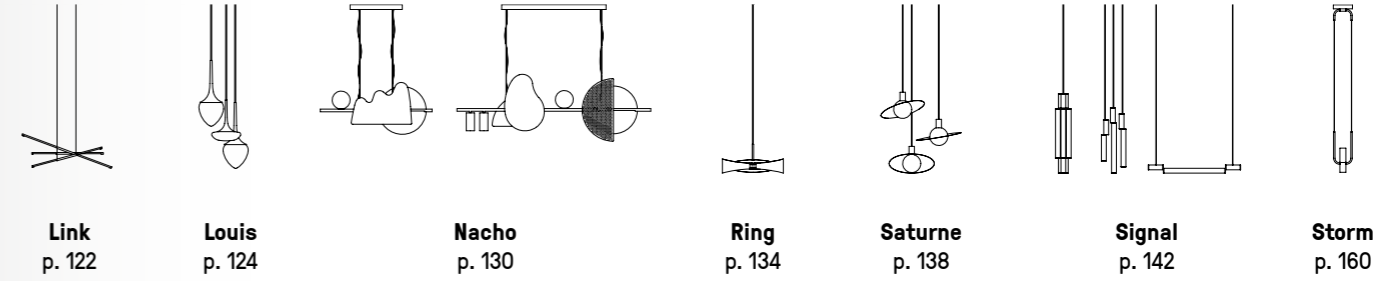

**Link** p. 122  
**Louis** p. 124  
**Nacho** p. 130  
**Ring** p. 134  
**Saturne** p. 138  
**Signal** p. 142  
**Storm** p. 160

APPLIQUES  
WALL LIGHTS

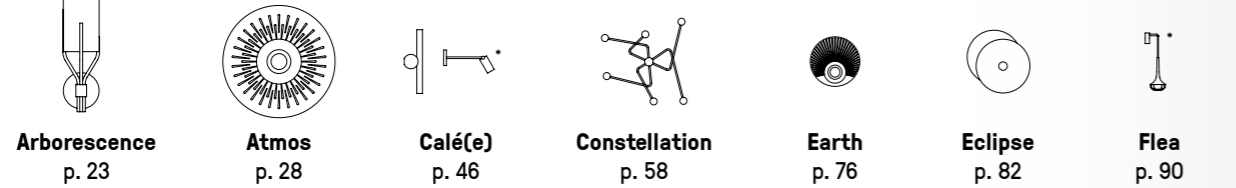

**Arborescence** p. 23  
**Atmos** p. 28  
**Calé(e)** p. 46  
**Constellation** p. 58  
**Earth** p. 76  
**Eclipse** p. 82  
**Flea** p. 90

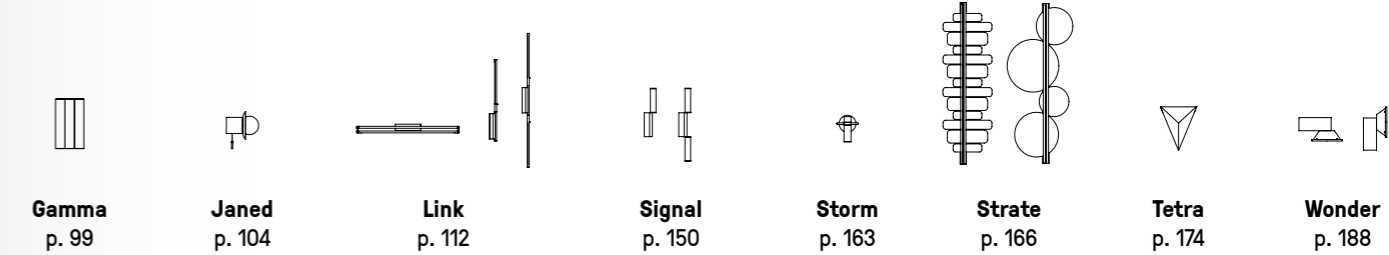

**Gamma** p. 99  
**Janed** p. 104  
**Link** p. 112  
**Signal** p. 150  
**Storm** p. 163  
**Strate** p. 166  
**Tetra** p. 174  
**Wonder** p. 188

LAMPADAIRES  
FLOOR LAMPS

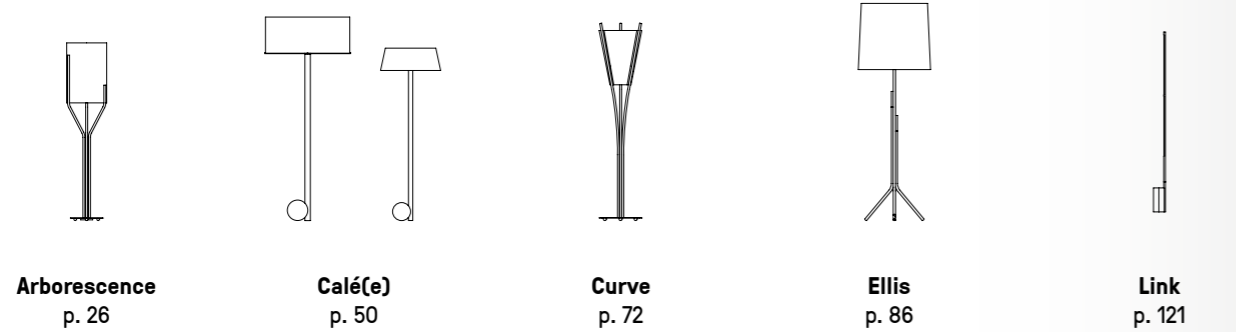

**Arborescence** p. 26  
**Calé(e)** p. 50  
**Curve** p. 72  
**Ellis** p. 86  
**Link** p. 121

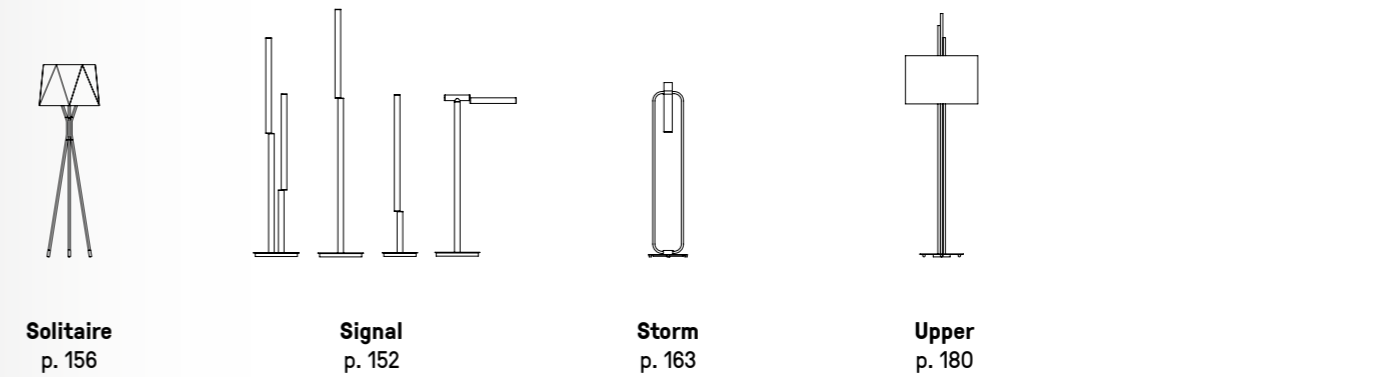

**Solitaire** p. 156  
**Signal** p. 152  
**Storm** p. 163  
**Upper** p. 180

LAMPES DE TABLE  
TABLE LAMPS

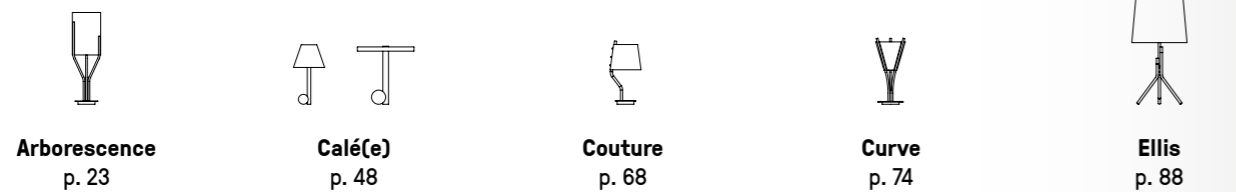

**Arborescence** p. 23  
**Calé(e)** p. 48  
**Couture** p. 68  
**Curve** p. 74  
**Ellis** p. 88

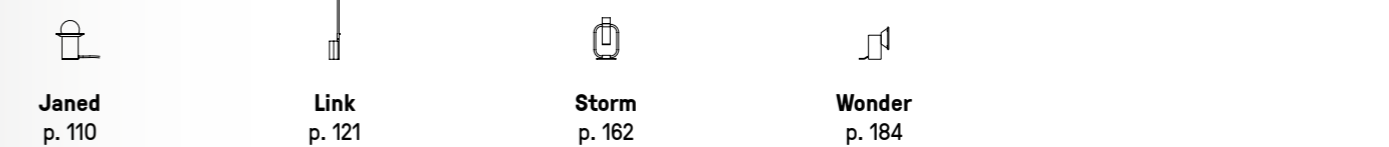

**Janed** p. 110  
**Link** p. 121  
**Storm** p. 162  
**Wonder** p. 184

SALLE DE BAIN  
BATHROOM

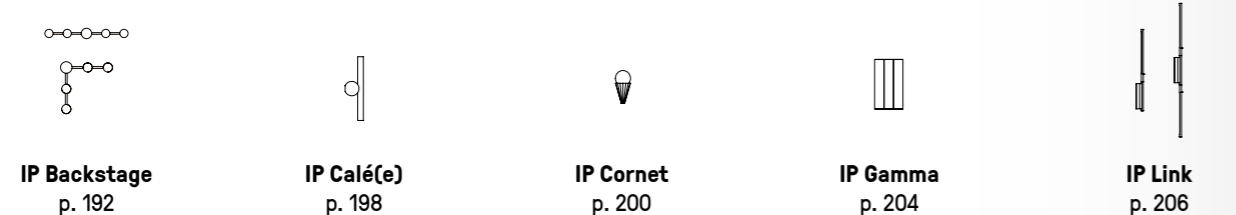

**IP Backstage** p. 192  
**IP Calé(e)** p. 198  
**IP Cornet** p. 200  
**IP Gamma** p. 204  
**IP Link** p. 206

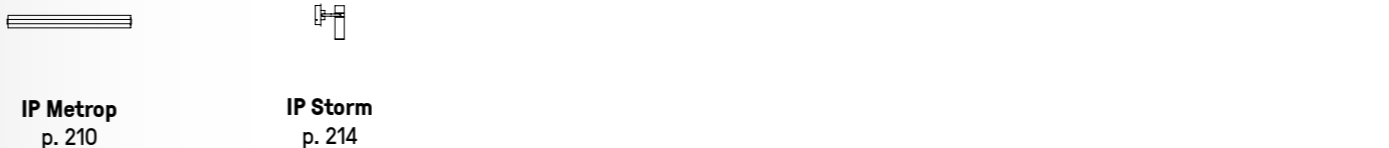

**IP Metrop** p. 210  
**IP Storm** p. 214

\* Currently not available in the US



## ARBORESCENCE

Collection ouverte, *Arborescence* est une gamme complète qui se décline en différentes dimensions. Évolutive, vous avez la possibilité de vous orienter sur du sur-mesure.



One of our most popular collections, *Arborescence* is a complete range in a variety of sizes and finishes. As a flexible concept, you can customize the light into a bespoke product.

**Finitions**  
**Finishes**

Détails page 222

● Laiton satiné SB Satin brass	● Graphite satiné SG Satin graphite	● Nickel satiné SN Satin nickel	● Cuivre satiné SC Satin copper
● Laiton poli PB Polished brass	● Graphite poli PG Polished graphite	● Nickel poli PN Polished nickel	● Cuivre poli PC Polished copper

**Abat-jour**  
**Lampshade**

□ Drop Paper® 100    ■ Drop Paper® 101    ■ Drop Paper® 103

**Matériaux**  
**Material**

<b>Tous – All</b> Laiton massif Solid Brass	<b>Tous – All</b> Abat-jour Drop Paper® M1 Lampshade Drop Paper® M1	<b>Lampes de table – Table lamps</b> Câble textile noir (longueur ≈ 2 m) Black textile cable (length ≈ 79")
---	---	---

**Source**  
**Lamping**

**Suspensions – Pendant lights**  
 1 x E27 205 W max. Ampoule non fournie  
 1 x E27 205 W max. Bulb not included

1 x E26 type A 150 W. Bulb not included

Variation\*  
 Dimming\*



**Applique – Wall light XL**  
 1 x E27 105 W max. Ampoule non fournie  
 1 x E27 105 W max. Bulb not included

1 x E26 type A 100 W. Bulb not included

**Applique – Wall light XS**  
 1 x E27 75 W max. Ampoule non fournie  
 1 x E27 75 W max. Bulb not included

1 x E26 type A 60 W. Bulb not included

**Lampadaires – Floor lamps**  
 1 x E27 205 W max. Ampoule non fournie  
 1 x E27 205 W max. Bulb not included

Variateur à pied  
 Foot operated dimmer

Variation\*  
 Dimming\*

1 x E26 type A 150 W. Bulb not included

Foot operated switch



**Lampe de table – Table lamp**  
 1 x E27 105 W max. Ampoule non fournie  
 1 x E27 105 W max. Bulb not included

Interrupteur sur câble  
 Cable switch

1 x E26 type A 100 W. Bulb not included

Cable switch



**Designer**  
 Hervé Langlais

\* Les luminaires variables nécessitent l'utilisation d'ampoules compatibles avec la variation  
 All dimmable light fixtures require the use of compatible bulbs

**Applique – Wall light XL**

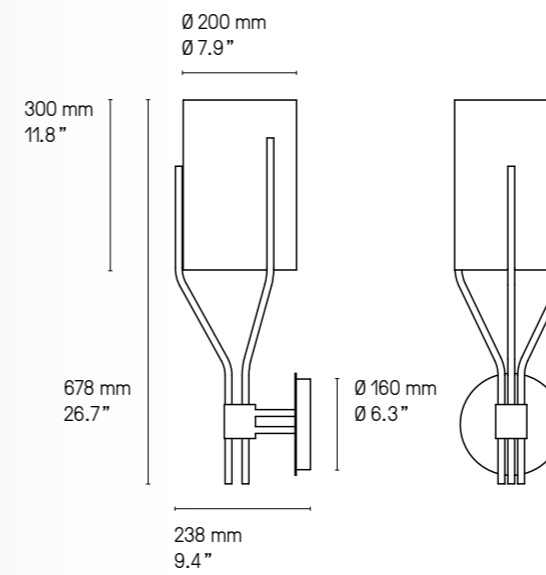

**Applique – Wall light XS**

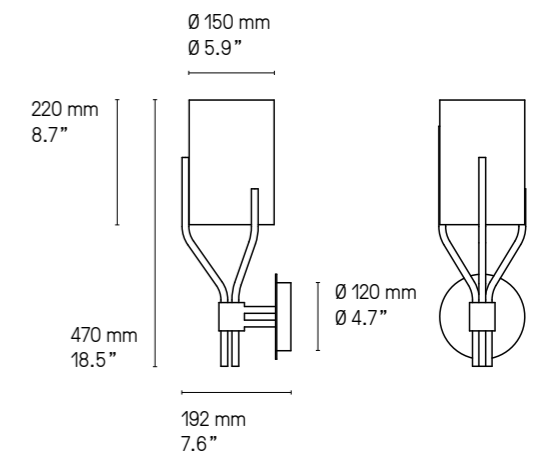

Applique – Wall light Arborescence XL SB

**Lampe de table – Table lamp**

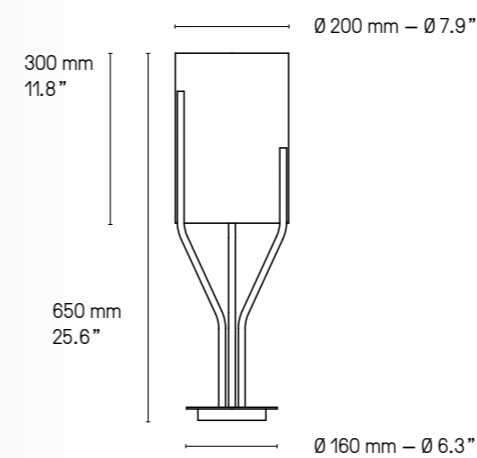

Lampe de table – Table lamp Arborescence SB

**Suspension – Pendant XXS**

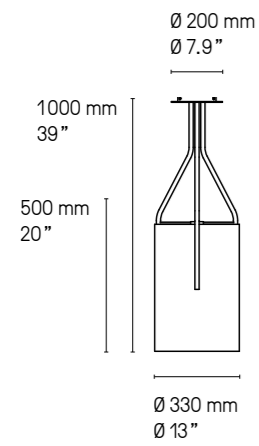

**Suspension – Pendant XS**

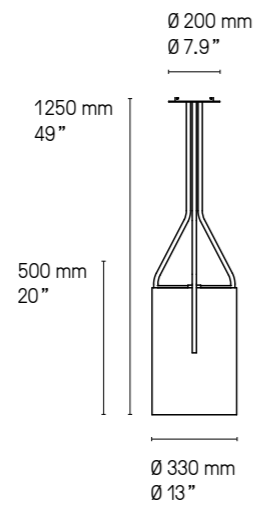

**Suspension – Pendant S**

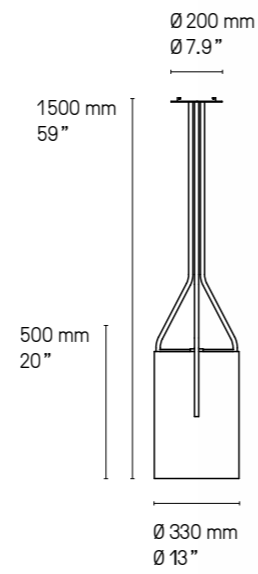

**Suspension – Pendant L**

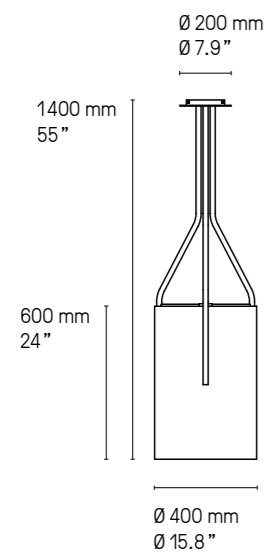

**Suspension – Pendant XL**

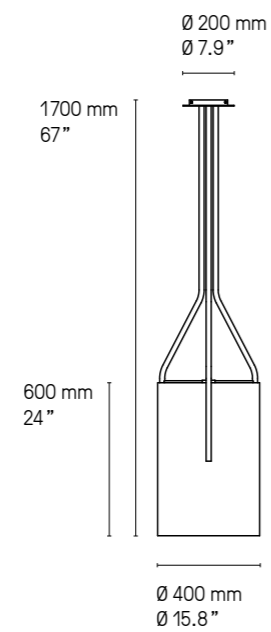

**Suspension – Pendant XXL**

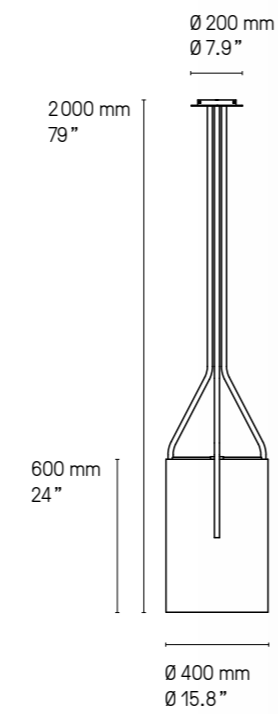

Hauteur sur mesure, version LED et DALI sur demande.  
Custom heights, LED and DALI version upon request.



Suspension – Pendant Arborescence XXS + XS + S PB

Lampadaire – Floor lamp **XXS**

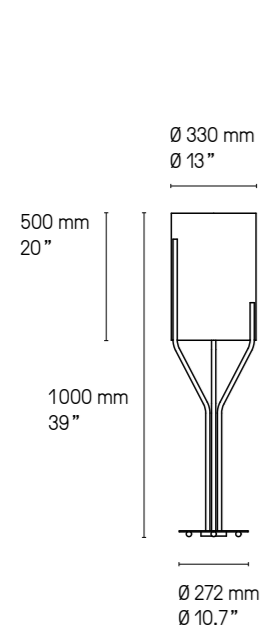

Lampadaire – Floor lamp **XS**

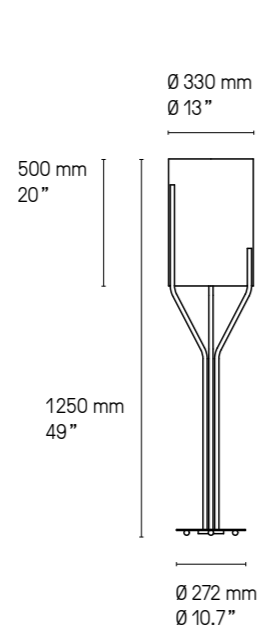

Lampadaire – Floor lamp **S**

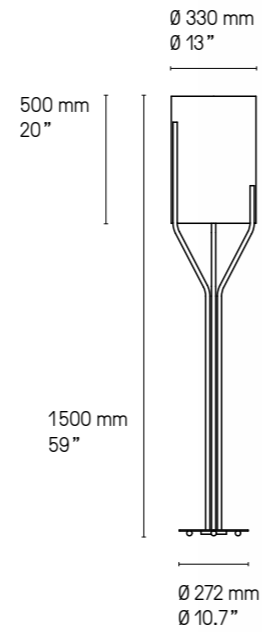

Lampadaire – Floor lamp **L**

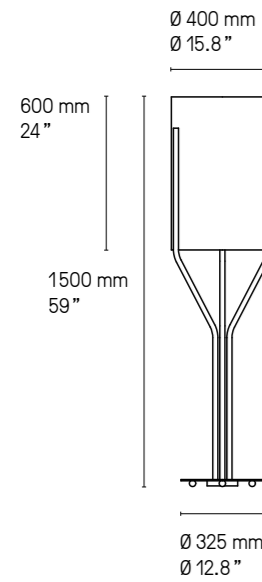

Lampadaire – Floor lamp **XL**

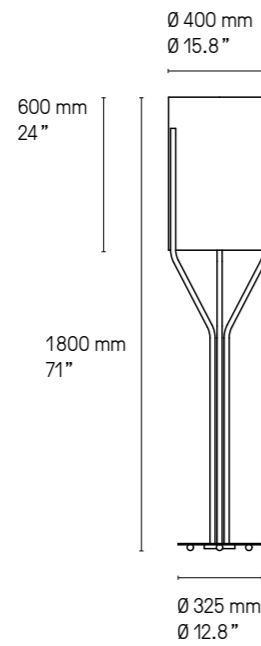

Lampadaire – Floor lamp **XXL**

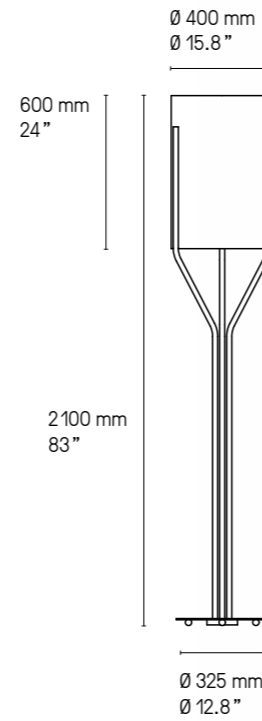

Hauteur sur mesure, version LED et DALI sur demande.  
Custom heights, LED and DALI version upon request.



Lampadaire – Floor lamp Arborescence XL + S SG



## ATMOS

Au centre de sa grande couronne ajourée, les disques concentriques d'*Atmos* se succèdent jusqu'à son cœur lumineux. Grande sœur de l'applique *Earth*, *Atmos* se distingue par sa grande taille et la multitude de combinaisons de décors possibles.



At the center of its large openwork crown, the concentric discs of *Atmos* follow one another up to its luminous heart. Big sister to the *Earth* wall lamp, *Atmos* is distinguished by its large size and the multitude of possible decor combinations.



**Finitions**  
**Finishes** ① + ② + ③ + ④

- Laiton satiné
- Graphite satiné
- Nickel satiné
- SB Satin brass
- SG Satin graphite
- SN Satin nickel

Détails page 222

**Matériaux**  
**Material** Laiton massif  
Solid brass

**Source**  
**Lamping** LED intégrée 1710 lm 2700°K Alim. électronique 24 V intégrée Variable (phase cut)  
Integrated LED 1710 lm 2700°K Integrated 24 V power supply Dimmable (phase cut)

**Designer** Émilie Cathelineau

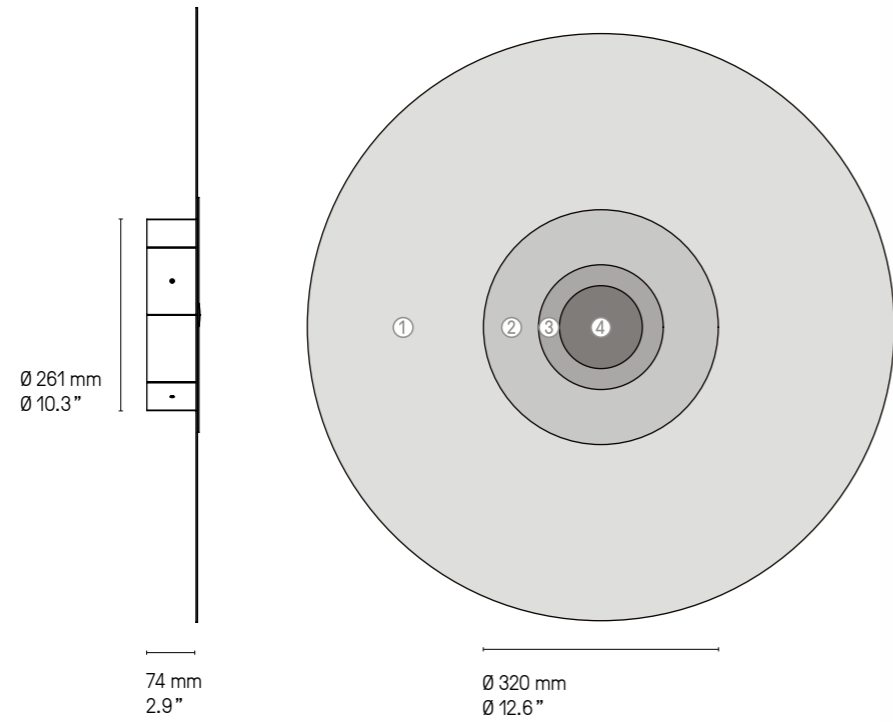

**Atmos Lace**

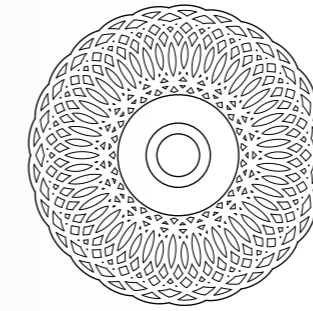

Ø 793 mm  
Ø 31.2"



Atmos Lace SB/SB/SG/SB

**Atmos Racine**

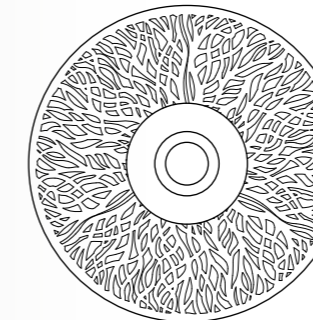

Ø 837 mm  
Ø 33"



Atmos Racine SB/SG/SG/SB



Atmos Racine SB/SG/SG/SB

Atmos Pop

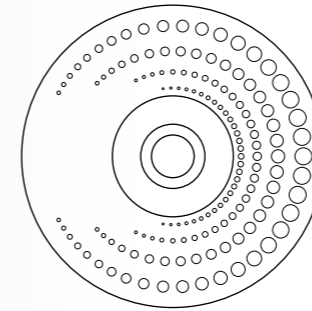

Ø 800 mm  
Ø 31.5"

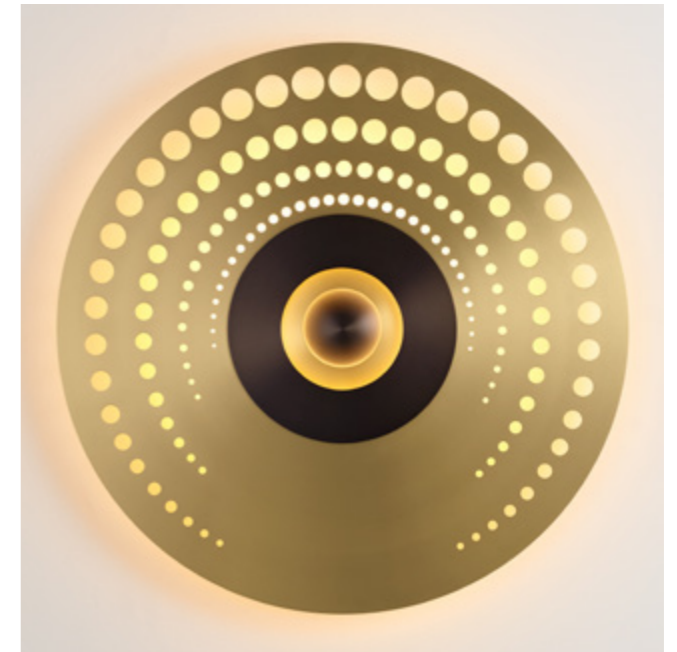

Atmos Pop SB/SG/SB/SG

Atmos Stella

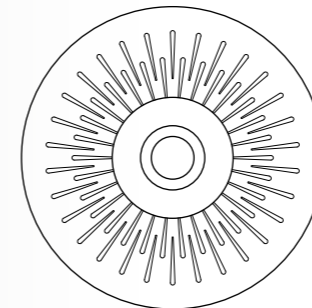

Ø 800 mm  
Ø 31.5"



Atmos Stella SG/SB/SG/SB



Atmos Éclat SB/SG/SB/SG



Atmos Éclat SB/SG/SB/SG

#### Atmos Éclat

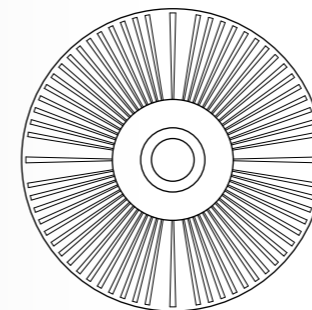

Ø 800 mm  
Ø 31.5"

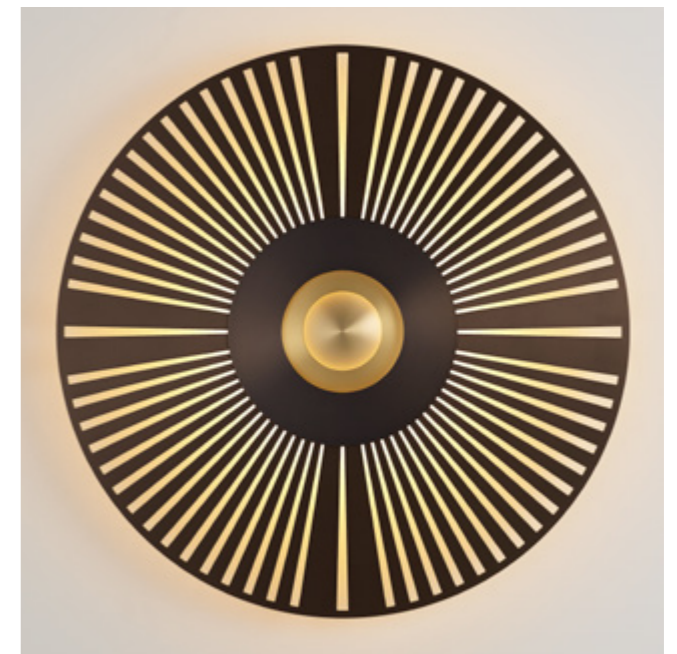

Atmos Éclat SG/SG/SB/SB



## CALÉ(E)

Alphabet de formes, la collection *Calé(e)* se décline en jeu géométrique où le sens du déséquilibre forme des objets simples, linéaires et raffinés.



An assembly of designs, the *Calé(e)* collection offers a range of geometric patterns where the sense of imbalance forms simple, linear and sophisticated objects.





Suspensions – Pendants Calé(e)

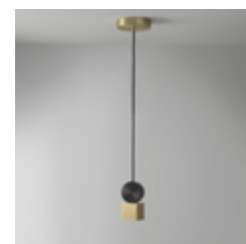
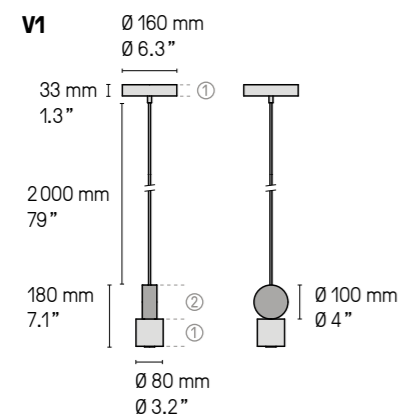

Calé(e) V1 SB/SG

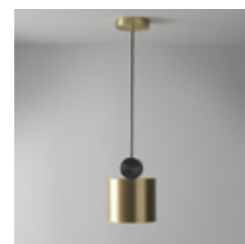
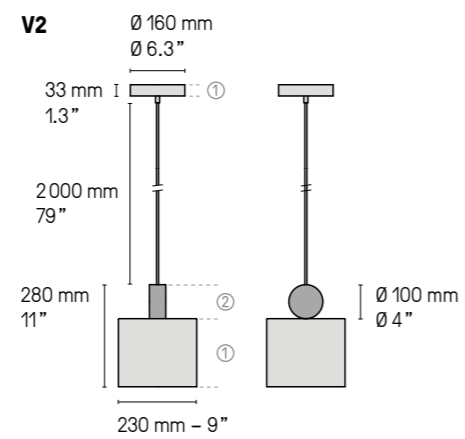

Calé(e) V2 SB/SG

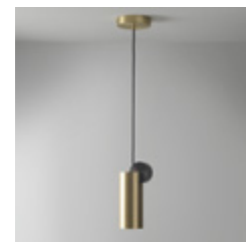
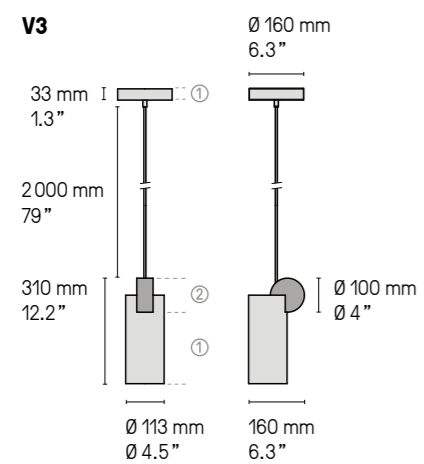

Calé(e) V3 SB/SG

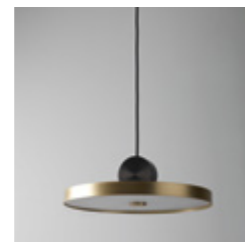
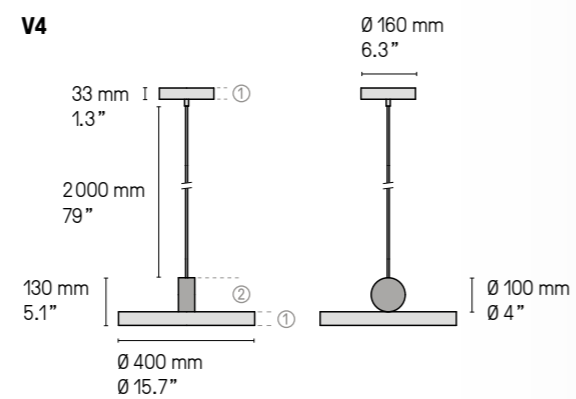

Calé(e) V4 SB/SG

Le petit disque du dessous sera toujours en finition ①  
The small centered disc on the bottom always comes in finish ①



Suspensions – Pendants Calé(e)

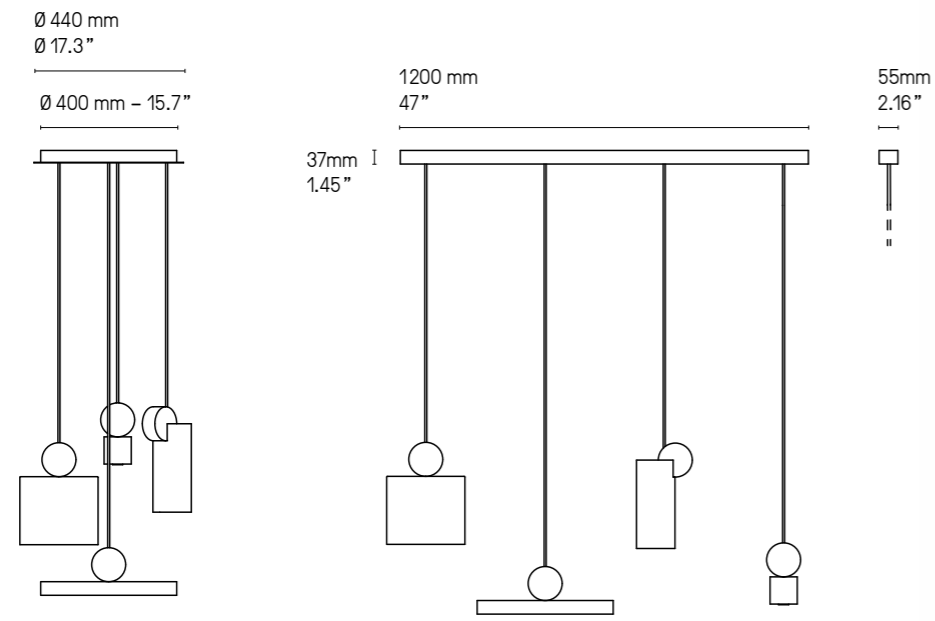

Calé(e) V2, V3 & V4 SB/SG



Calé(e) V1, V2 & V3 SG/SB



**Appliques – Wall lights Calé(e)**

**VH**

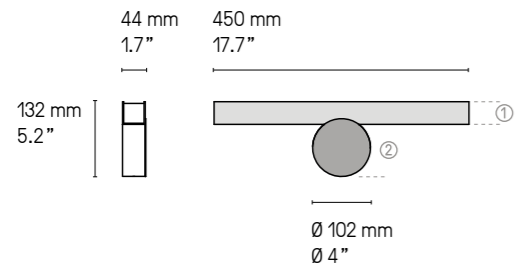

**VV**

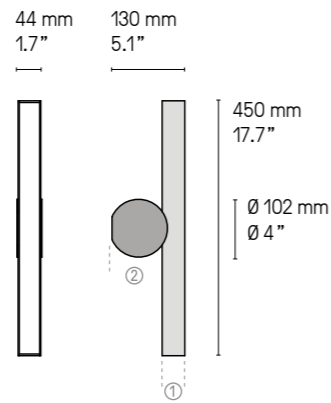

**VF**

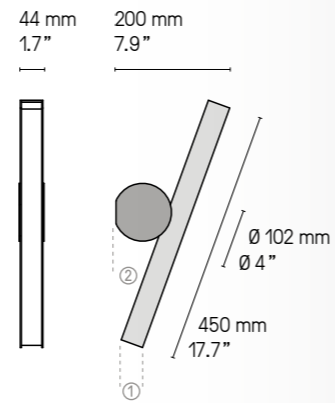

**US Version  
fitted plate to cover outlet power box**

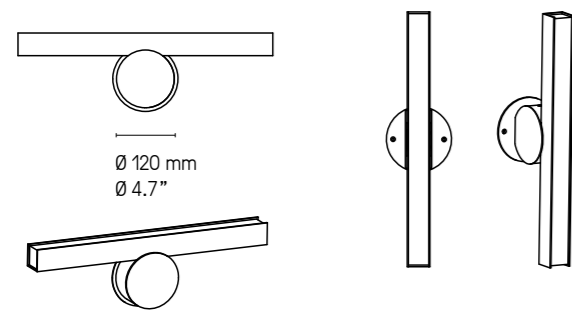

Les appliques Calé(e)s ne sont pas réglables. Ce sont 3 modèles différents.  
Retrouvez les variantes salle de bain (IP44) de ces modèles p.198  
Calé(e) wall lights are not mobile. These are 3 different fixed models.  
You will find the bathroom variants (IP44) of these designs p.198

**Spot XL**

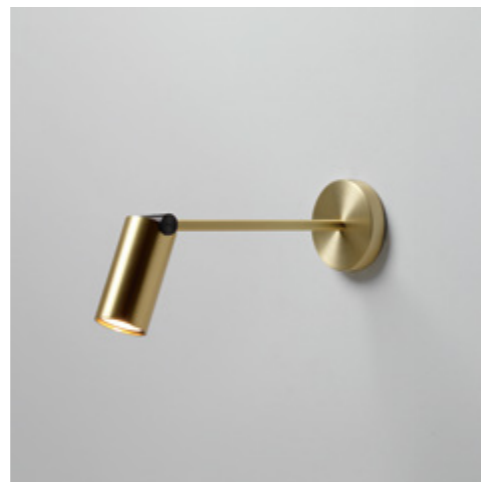
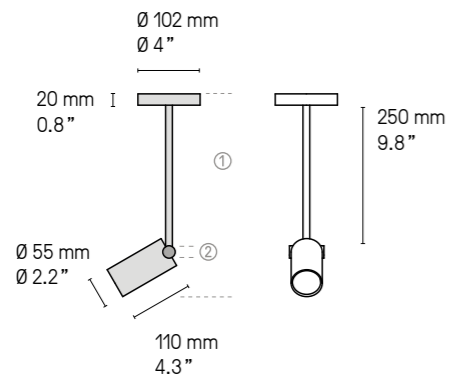

Spot Calé(e) XL SB/SG



Applique – Wall light Calé(e) VF SB/SG



Applique – Wall light Calé(e) VV SG/SB

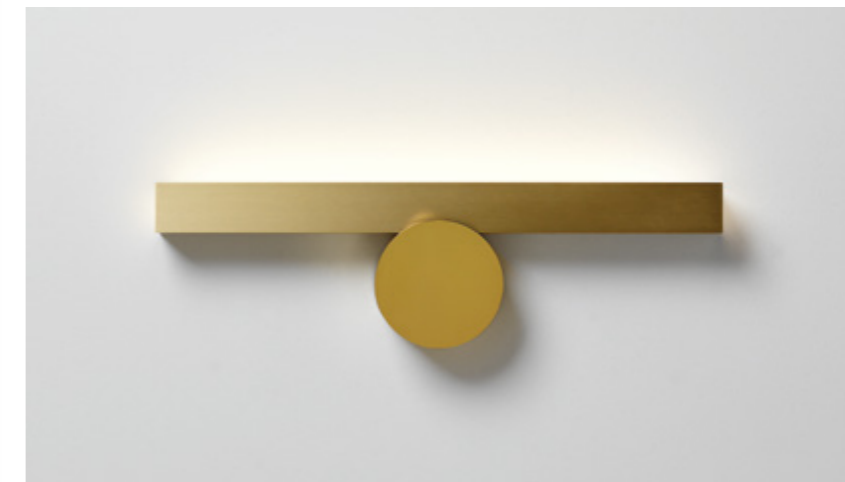

Applique – Wall light Calé(e) VH SB/PB

Lampe de tables – Table lamps Calé(e)

**XL**

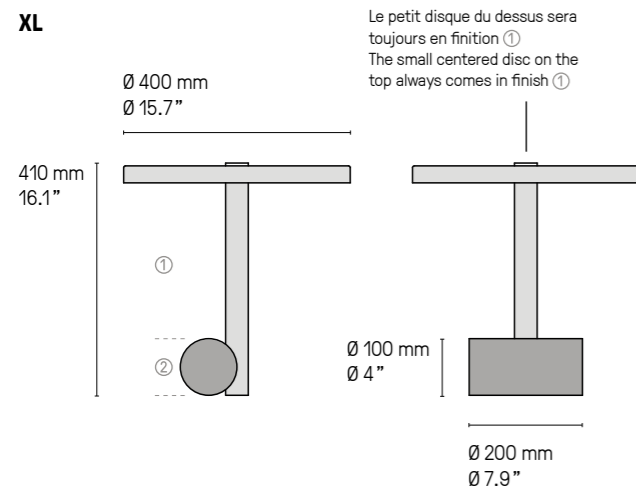

**XS**

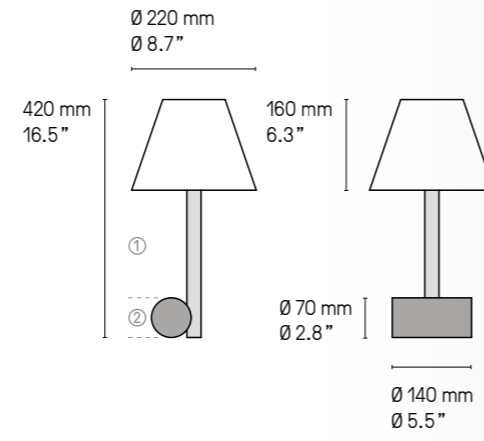

Lampe Calé(e) XS SN/SG



Lampadaires – Floor lamp Calé(e)

**XL**

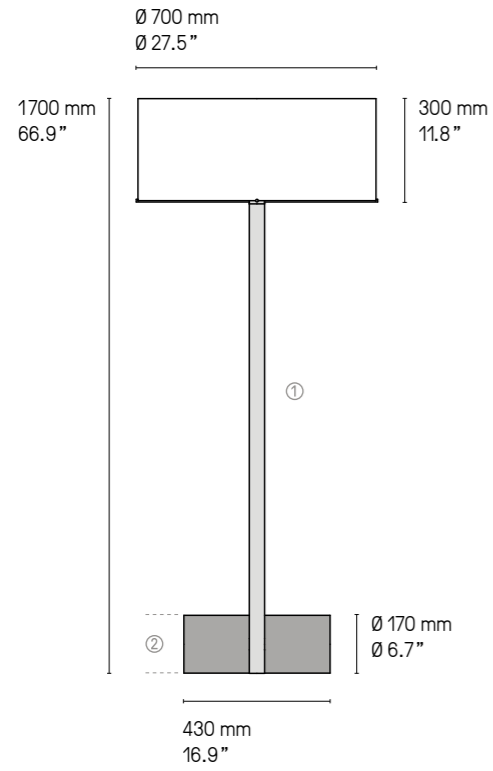

**XS**

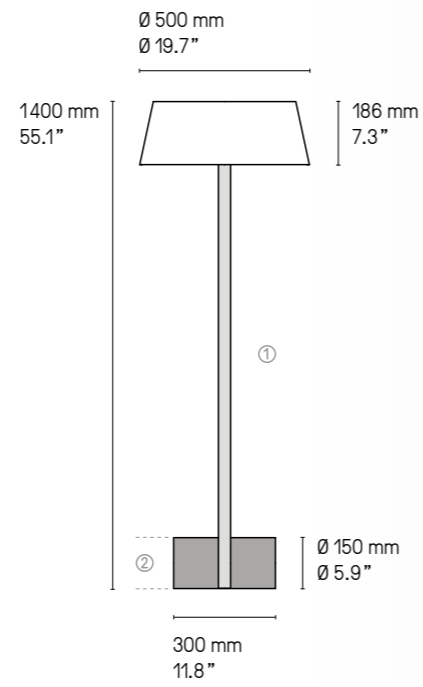

Version LED et DALI sur demande.  
LED and DALI version upon request.



Calé(e) XL SB/SG



Lampadaire – Floor lamp Calé(e) XS SB/SB



## CERCLE & TRAIT

D'une apparente légèreté, les formes de *Cercle & trait* se frottent et se tiennent dans un jeu d'équilibre savamment dosé. Une suspension graphique déclinée en différentes finitions qui ne tient qu'à un fil.



As light as it looks, the forms of *Cercle & trait* rub together and hold together in a cleverly measured balance. A graphic pendant, available in different finishes, is just held by one small wire.

**Finitions**  
**Finishes**

- Laiton satiné  
SB Satin brass
- Graphite satiné  
SG Satin graphite
- Nickel satiné  
SN Satin nickel
- Cuivre satiné  
SC Satin copper

Détails page 222

**Matériaux**  
**Material**

- Laiton massif  
Solid Brass
- Diffuseur en polycarbonate blanc  
White polycarbonate diffuser
- Câble textile noir (longueur ≈ 1 m)  
Black textile cable (length ≈ 39.4")

**Source**  
**Lamping**

- Suspension – Pendant XL**  
 LED 1350 lm 2700°K
  - Alim. 24 V intégrée dans le pavillon  
 Int. power supply 24 V included in canopy
  - Variable (phase cut)  
 Dimmable (phase cut)
  - 
- 
- Suspension – Pendant XS**  
 LED 900 lm 2700°K
  - Alim. 24 V intégrée dans le pavillon  
 Int. power supply 24 V included in canopy
  - Variable (phase cut)  
 Dimmable (phase cut)

**Designer** POOL

**Cercle & trait XL**

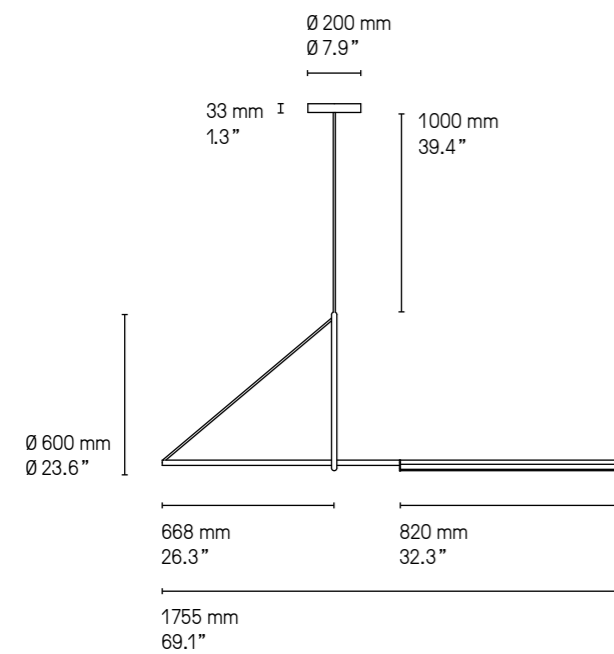
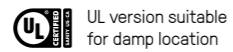

**Cercle & trait XS**

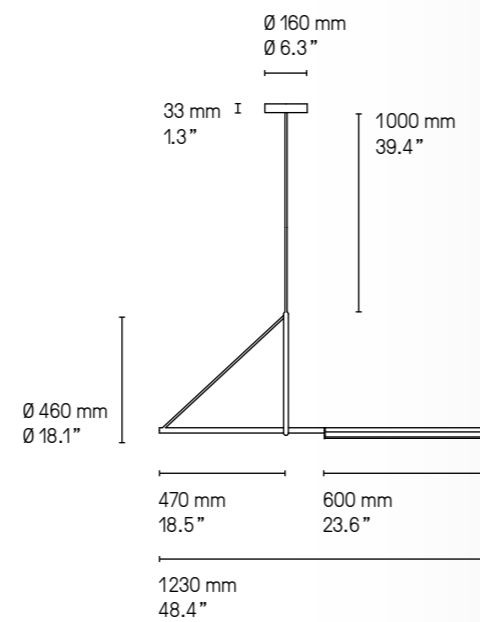

Cercle & trait est un projet sur le mouvement des formes et l'équilibre qui s'entremêlent.  
 Ce luminaire comme un mobile crée une lumière en mouvement.  
 Cercle & trait is a design between movement of forms and balance that intertwine.  
 Like a mobile this luminaire creates a light in motion.



Cercle & trait XL SG





## CONSTELLATION

Asymétrie et démultiplication, *Constellation* offre une infinité de possibilités à composer selon l'espace et vos inspirations. En mural ou au plafond, vos envies se dessinent en points lumineux.



Asymmetry and multiplying, *Constellation* offers an infinity of arrangement possibilities depending on the space and your inspirations. As a wall unit or a ceiling fixture, you can position the light any way you desire to.

**Finitions**  
**Finishes** ①

Détails page 222

**Finitions**  
**Finishes** ②

● Laiton satiné  
SB Satin brass

● Graphite satiné  
SG Satin graphite

● Nickel satiné  
SN Satin nickel

● Laiton satiné  
SB Satin brass

● Graphite satiné  
SG Satin graphite

● Nickel satiné  
SN Satin nickel

● Cuivre satiné  
SC Satin copper

**Matériaux**  
**Material**

Laiton massif  
Solid Brass

Verre triplex opale soufflé bouche  
Opal triplex mouth-blown glass

**Source**  
**Lamping**

LED intégrée 6 x 120 lm 3000°K  
Integrated LED 6 x 120 lm 3000°K

Alimentation intégrée fournie  
Integrated power supply included

ou - or  
Alimentation séparée fournie  
Remote power supply included

Variation. Veuillez nous contacter  
Dimming. Please, contact us



**Designer**

Émilie Cathelineau

**Alimentation intégrée**  
**Integrated power supply**

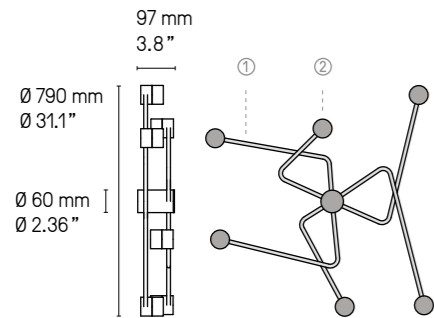

**Alimentation séparée**  
**Remote power supply**

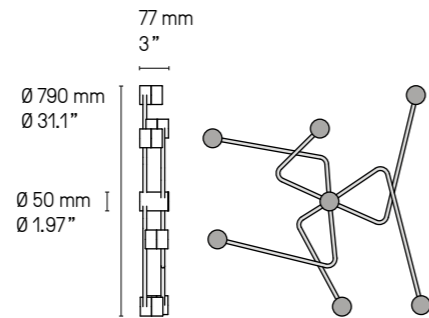

**UL Version**  
**fitted plate to cover outlet power box**

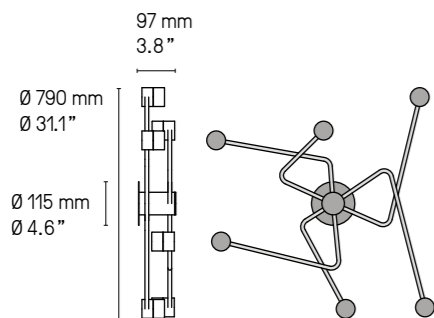

Constellation  
SG/SB

**Exemples de compositions, avec 3, 5 et 8 modules**  
**Examples of arrangements, with 3, 5 or 8 units**

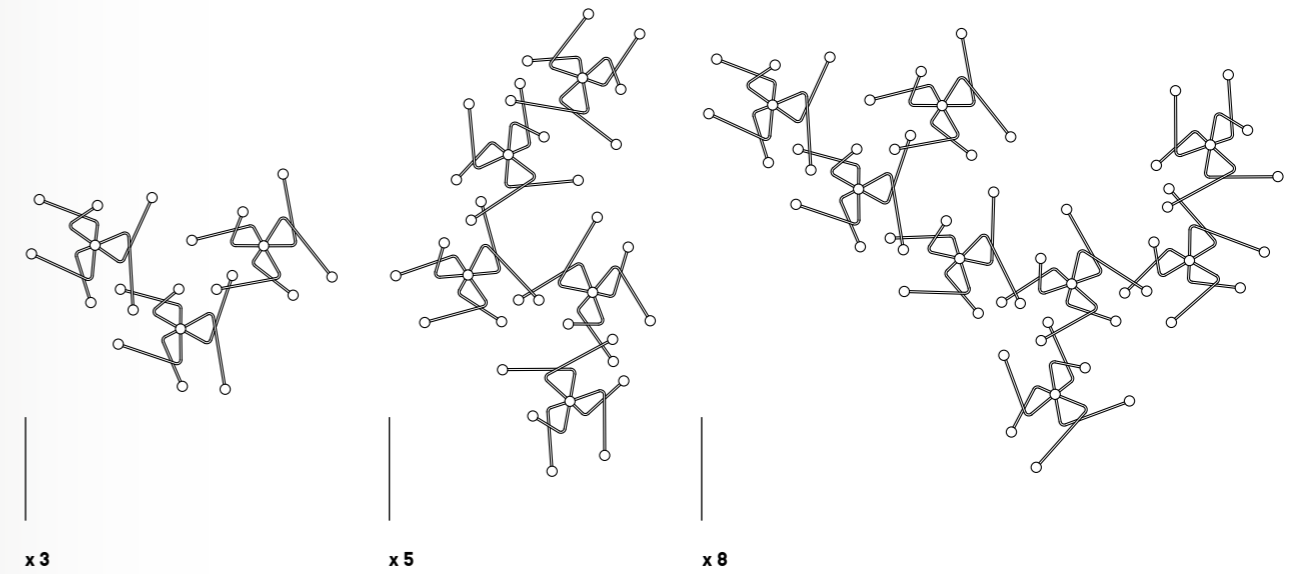

**Version interconnectée**  
**Interconnected version**

Ce système d'interconnection ne nécessite qu'une seule sortie électrique. Veuillez noter que cette version interconnectée n'est pas certifiée UL et que les points de connections ne sont pas lumineux. Merci de nous contacter pour connaître les compositions possibles.

The new interconnection system requires only one electrical outlet. Please be aware that this interconnected system is not yet UL certified and that the connection points have no light. Contact us for more information on possible arrangements.

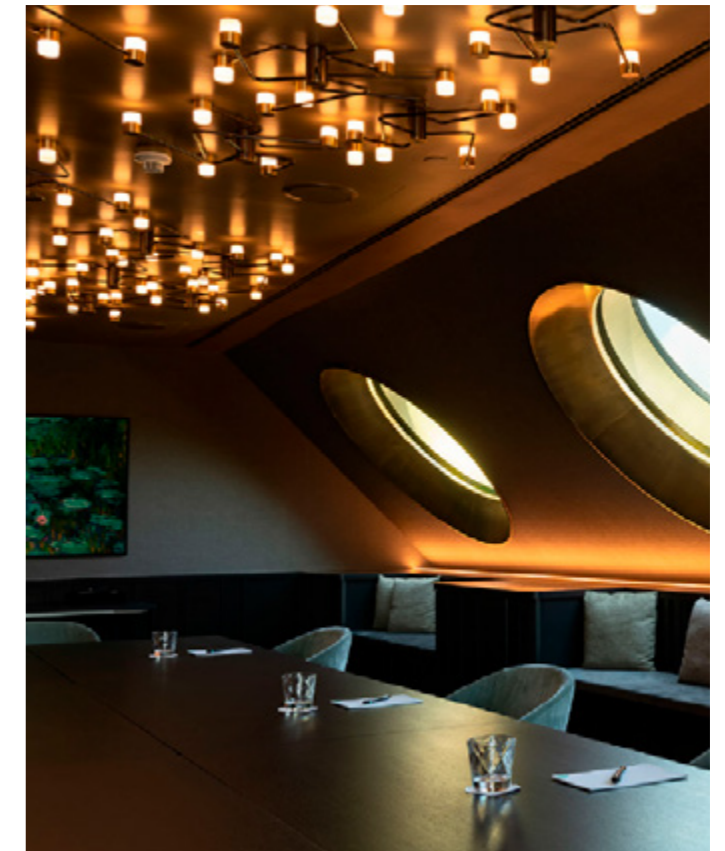
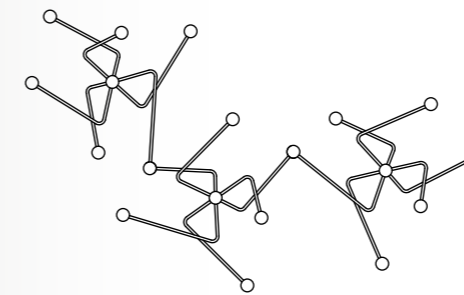

Constellations SG/SB indépendantes





## CORNET

Luminaire à la fois minimaliste et ludique grâce à la technique du pliage du laiton. Chacune des facettes met la matière en valeur. La suspension, au design ovale et conique, peut accueillir trois ou cinq boules en verre opale.



A light that is both minimalist and playful thanks to the technique of folding the material of brass. Each of the facets really highlight the material. The pendant, with an oval and conical design, can accommodate three or five opal glass balls.

**Finitions  
Finishes**

Détails page 222

**Suspensions – Pendants**

- |  |   |   |   |
|--|---|---|---|
| ● Laiton satiné<br><b>SB</b> Satin brass | ● Graphite satiné<br><b>SG</b> Satin graphite | ● Nickel satiné<br><b>SN</b> Satin nickel | ● Cuivre satiné<br><b>SC</b> Satin copper |
|--|---|---|---|

**Appliques – Wall mounted lights**

- |   |  |  |  |
|---|--|--|--|
| ● Laiton satiné<br><b>SB</b> Satin brass  | ● Graphite satiné<br><b>SG</b> Satin graphite  | ● Nickel satiné<br><b>SN</b> Satin nickel  | ● Cuivre satiné<br><b>SC</b> Satin copper  |
| ● Laiton poli<br><b>PB</b> Polished brass | ● Graphite poli<br><b>PG</b> Polished graphite | ● Nickel poli<br><b>PN</b> Polished nickel | ● Cuivre poli<br><b>PC</b> Polished copper |

**Matériaux  
Material**

- |                              |  |
|------------------------------|--|
| <b>Tous – All</b>            | <b>Suspensions – Pendants</b>  |
| Laiton massif<br>Solid Brass | Verre triplex opale<br>Opal triplex glass  |
|                              | Câble textile noir + câble métallique (longueur ≈ 2 m)<br>Black textile cable + metal cable (length ≈ 79") |

**Source  
Lamping**

**Suspension – Pendant light**

**Suspension CORNET 3L**

G9 Led 3x 5W max. non fournie  
G9 Led 3x 5W max. not included

Variable\*  
Dimmable\*

Variable\*  
Dimmable\*

**Suspension CORNET 5L**

G9 Led 5x 5W max. non fournie  
G9 Led 5x 5W max. not included

Variable\*  
Dimmable\*

Variable\*  
Dimmable\*

**Appliques – Wall mounted lights**

G9 LED 5W max. non fournie  
G9 LED 5W max. not included

Variable\*  
Dimmable\*

Norme IP24 Classe II  
IP24 Class II standard

**Designer**

POOL

\* Les luminaires variables nécessitent l'utilisation d'ampoules compatibles avec la variation  
All dimmable light fixtures require the use of compatible bulbs

**IP Cornet Appliques – Wall mounted lights**

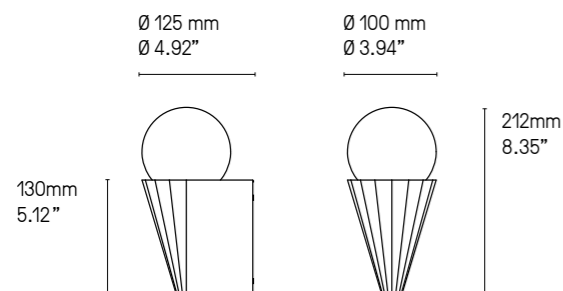

Appliques – Wall mounted lights  
Cornet SN

**Cornet 3 L Suspension – Pendant**

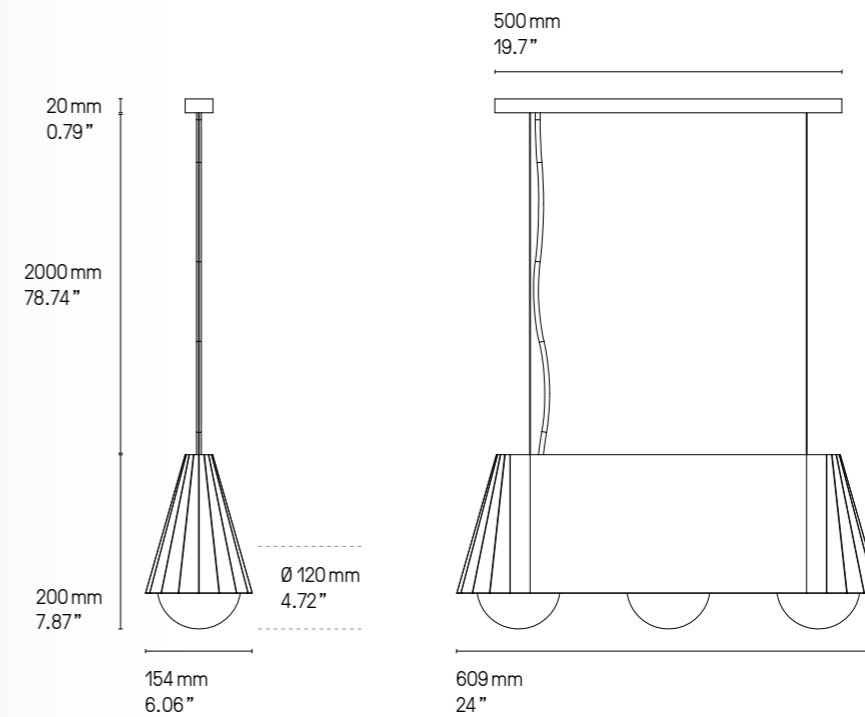

**Cornet 5 L Suspension – Pendant**

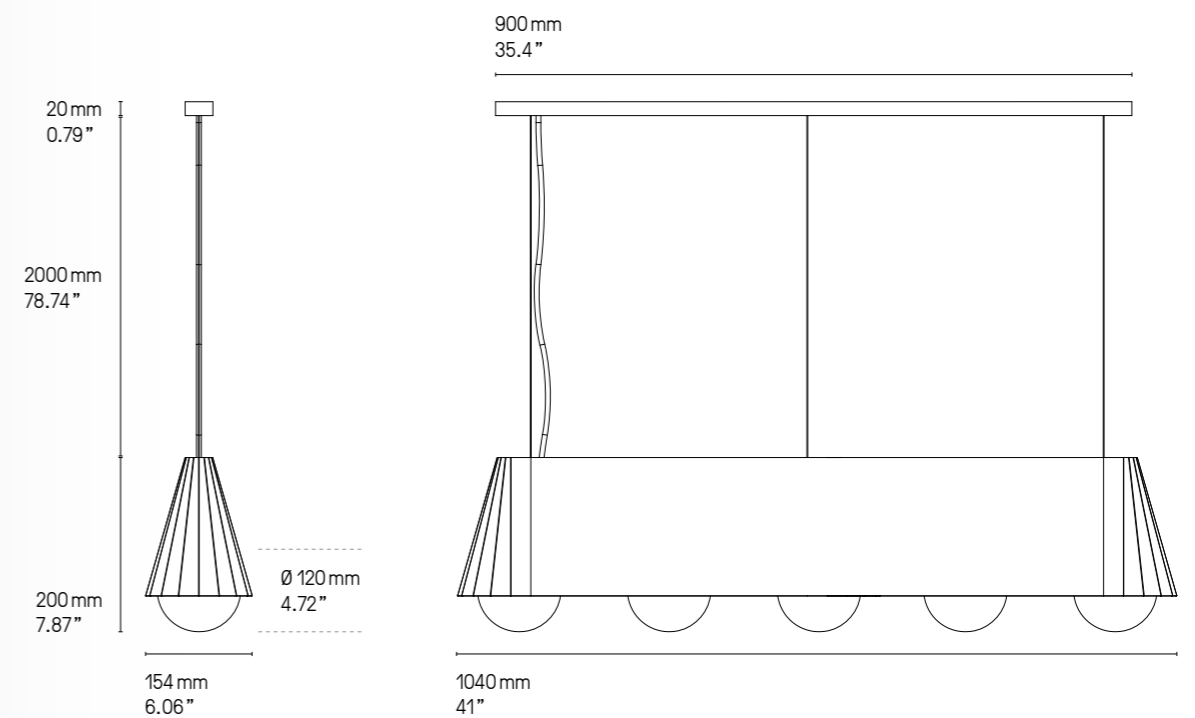

La longueur des câbles est réglable à l'installation.  
The height of the cables can be adjusted during installation.



Suspension – Pendant light Cornet 3 L SB



Appliques – Wall mounted lights Cornet SG



## COUTURE

Discrète et raffinée, *Couture* est une petite lampe à poser dont l'abat-jour est tout simplement boutonné sur sa tige courbée en laiton.

Sa silhouette toujours changeante à l'élégance classique en fait une pièce stylée pour l'intérieur.











Discrete and refined, *Couture* is a small table lamp with a shade that is simply buttoned to its curved brass stem.

Its ever-changing profile and classic elegance make it a stylish piece for interiors.

**Finitions  
Finishes**

Détails page 222

 Laiton satiné SB Satin brass	 Graphite satiné SG Satin graphite	 Nickel satiné SN Satin nickel	 Cuivre satiné SC Satin copper
 Laiton poli PB Polished brass	 Graphite poli PG Polished graphite	 Nickel poli PN Polished nickel	 Cuivre poli PC Polished copper

**Abat-jour  
Lampshade**

<input type="checkbox"/> Drop Paper® 100	<input type="checkbox"/> Drop Paper® 101	<input type="checkbox"/> Drop Paper® 103
<input type="checkbox"/> Chinette blanche White chinette		

**Matériaux  
Material**

Laiton massif Solid Brass	Abat-jour Drop Paper® M1 Lampshade Drop Paper® M1	Câble textile noir (longueur ≈ 2 m) Black textile cable (length ≈ 79")
------------------------------	--	---

**Source  
Lamping**

1 x E14 40W max. Ampoule non fournie 1 x E14 40W max. Bulb not included	Interrupteur sur câble Cable switch
--	--

**Designer**

Hervé Langlais

**Lampe de table – Table lamp**

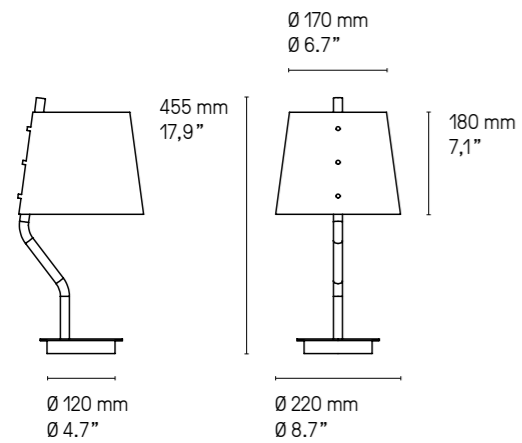

En standard, le dessous de la base sera toujours en finition graphite, si vous préférez une autre finition, merci de le préciser.

As standard, the underside of the base always comes in a satin graphite finish unless specified differently.



Lampe de table – Table lamp Couture SB



Lampe de table – Table lamp Couture SG



## CURVE

Trois formats viennent composer cette collection aux lignes singulières. Les deux lampadaires et la lampe *Curve* s'agencent autour d'un abat-jour triangulaire incurvé prolongé par la ligne du pied.



The lights of this collection are each composed of three formats with unique lines. Both the *Curve* floor lamps and Lamp arrange themselves around a triangular curved lampshade.

**Finitions**  
**Finishes**

Détails page 222

- |                                    |   |                                     |                                     |
|------------------------------------|---|-------------------------------------|-------------------------------------|
| ● Laiton satiné<br>SB Satin brass  | ● Graphite satiné<br>SG Satin graphite  | ● Nickel satiné<br>SN Satin nickel  | ● Cuivre satiné<br>SC Satin copper  |
| ● Laiton poli<br>PB Polished brass | ● Graphite poli<br>PG Polished graphite | ● Nickel poli<br>PN Polished nickel | ● Cuivre poli<br>PC Polished copper |

**Abat-jour**  
**Lampshade**

- |  |   |
|--|---|
| <input checked="" type="checkbox"/> Duke<br>Duke | <input type="checkbox"/> Chinette blanche<br>White chinette |
|--|---|

**Matériaux**  
**Material**

- |                              |                                      |   |
|------------------------------|--------------------------------------|---|
| Laiton massif<br>Solid Brass | Abat-jour tissu<br>Textile lampshade | Câble textile noir (longueur ≈ 2 m)<br>Black textile cable (length ≈ 79") |
|------------------------------|--------------------------------------|---|

**Source**  
**Lamping**

- |  |  |                        |
|--|--|------------------------|
| <b>Lampadaire – Floor lamp</b><br>1 x E27 205W max. Ampoule non fournie<br>1 x E27 205W max. Bulb not included | Variateur à pied<br>Foot operated dimmer | Variation*<br>Dimming* |
| 1 x E26 type A 100W. Bulb not included   | Foot operated switch                     |                        |



**Lampe de table – Table lamp**  
1 x E27 60W max. Ampoule non fournie  
1 x E27 60W max. Bulb not included

Interrupteur sur câble  
Cable switch

1 x E26 type A 60W. Bulb not included

Cable switch



**Designer** Émilie Cathelineau

\* Les luminaires variables nécessitent l'utilisation d'ampoules compatibles avec la variation  
 All dimmable light fixtures require the use of compatible bulbs

**Curve lampe de table – Table lamp**

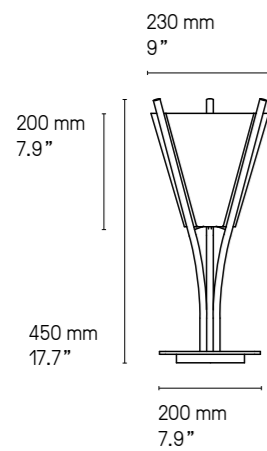

Lampe de table – Table lamp Curve SB

**Curve XL**

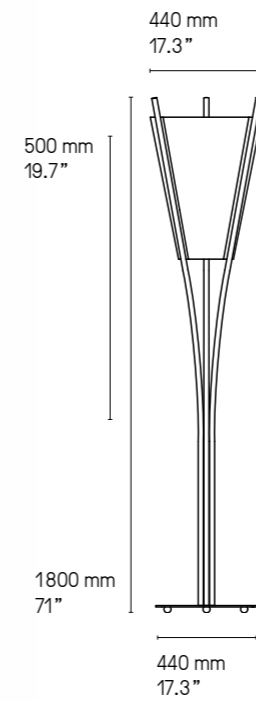

**Curve XS**

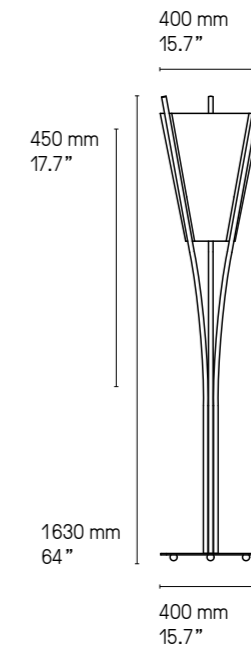

Version LED et DALI sur demande.  
 LED and DALI version upon request.



Lampadaire – Floor lamp Curve XL SB



Lampadaire – Floor lamp Curve XS SG

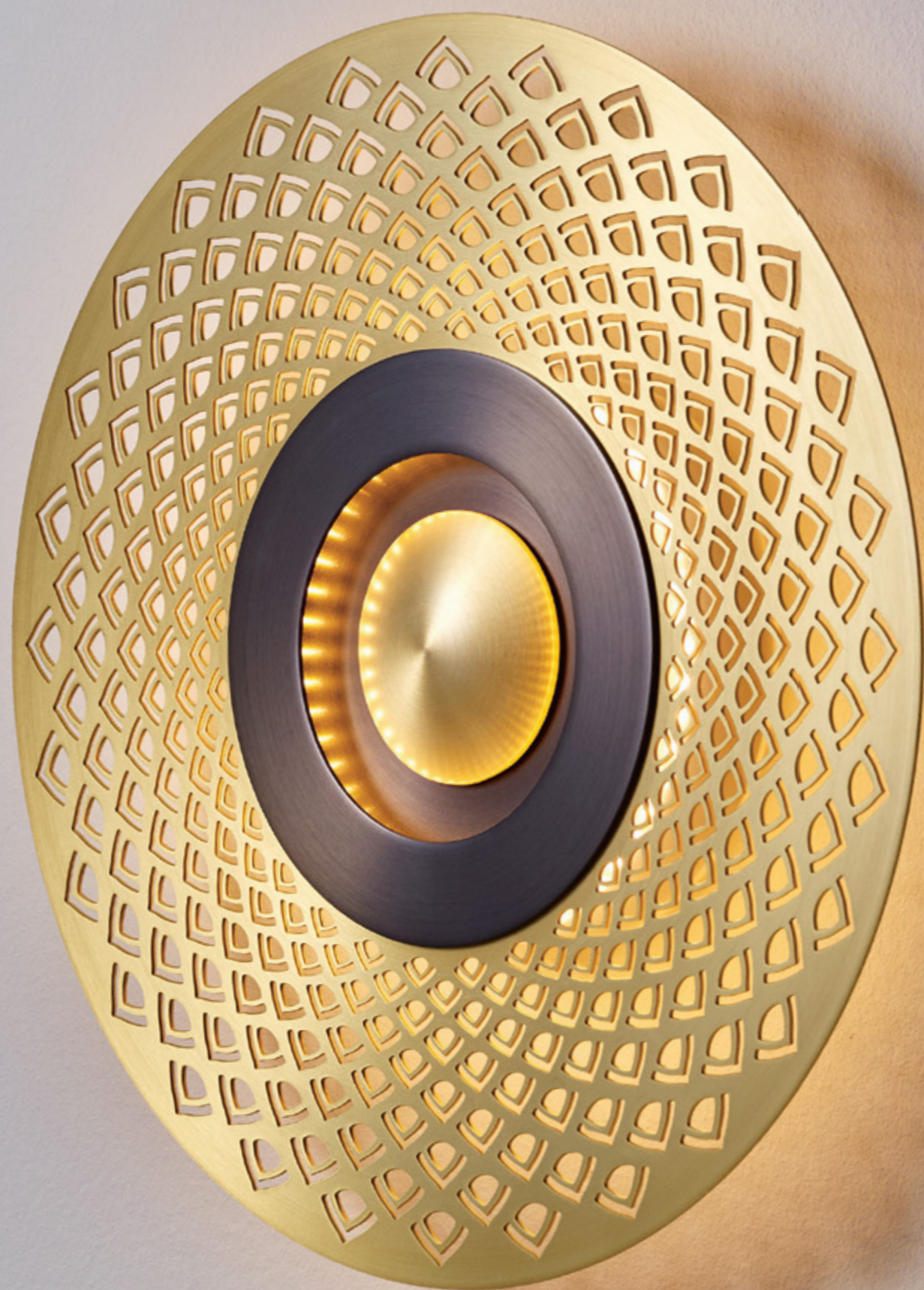

## EARTH

Un cœur lumineux, serti d'un métal ajouré de manière extrêmement fine ou d'un disque plein, confère à cette collection une touche Art déco. Du clair-obscur au moucharabieh, les idées de composition sont variées.



This wall light, with an illuminated center, assembled with an extremely fine openwork or a fully covered piece of metal gives this collection an Art déco style. From semi-darkness to a patterned light source, arrangements can vary.



**Finitions**  
**Finishes** ①+②

- Laiton satiné
- Graphite satiné
- Nickel satiné
- Cuivre satiné
- SB** Satin brass
- SG** Satin graphite
- SN** Satin nickel
- SC** Satin copper

Détails page 222

<b>Matériaux</b> <b>Material</b>	Laiton massif Solid brass	Diffuseur en polycarbonate Polycarbonate diffuser
-------------------------------------	------------------------------	--

<b>Source</b> <b>Lamping</b>	LED intégrée Integrated LED	1030 lm 1080 lm	2700°K 2700°K	Alim. électronique 24 V intégrée Integrated 24 V power supply	Variation. Veuillez nous contacter Dimming. Please, contact us	
---------------------------------	--------------------------------	--------------------	------------------	--	---	---

**Designer** Émilie Cathelineau

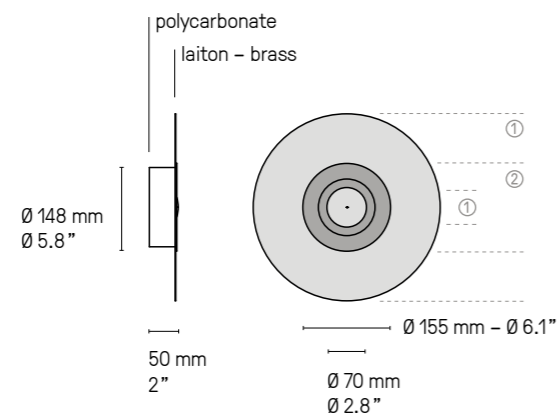

Partie centrale identique pour tous les modèles, quels que soient la taille et le motif.  
Identical central part for all *Earth* fixtures for any size and design.

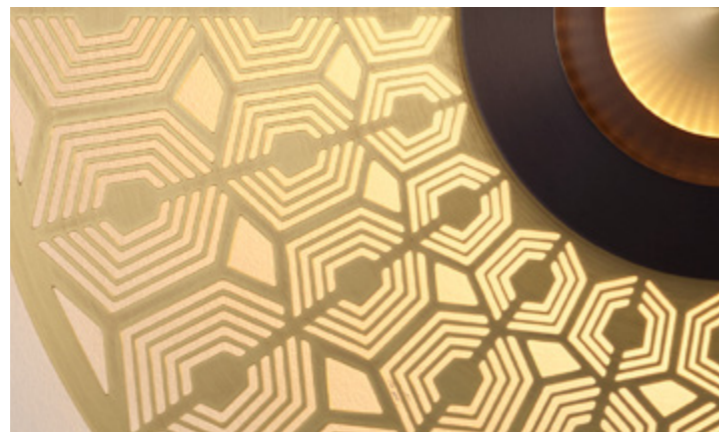

Earth Turtle 440 SB/SG

**Earth Sober** Ø 250 & Ø 330 mm

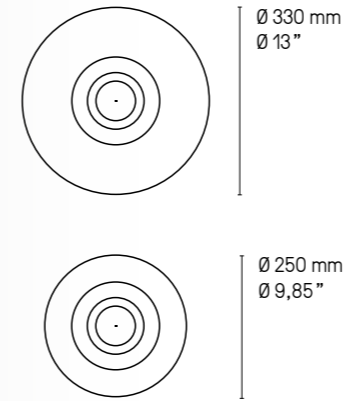

Earth Sober 330 SN/SG

**Earth Radian** Ø 350 mm

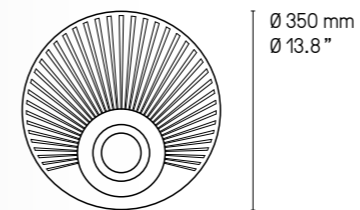

Earth Radian 350 SG/SB

Earth Mandala Ø 330 & Ø 440 mm

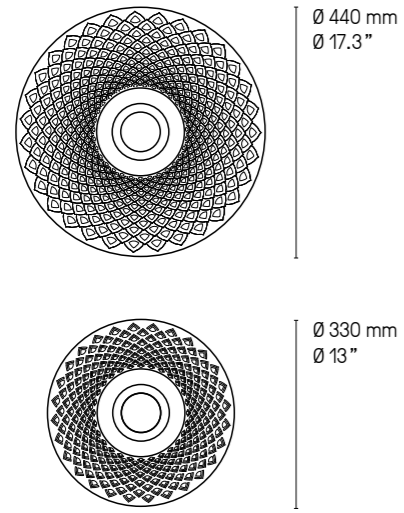

Earth Mandala 330 SB/SG

Earth Sun Ø 330 & Ø 440 mm

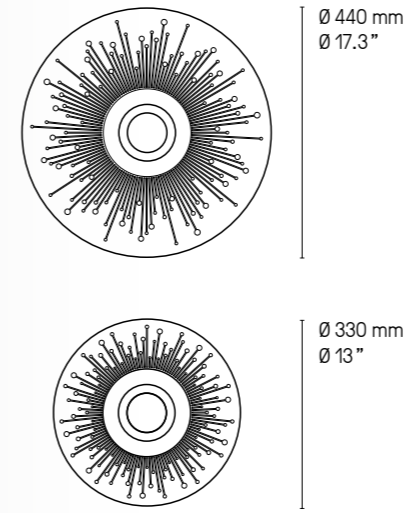

Earth Sun 330 SB/SG

Earth Palm Ø 330 & Ø 440 mm

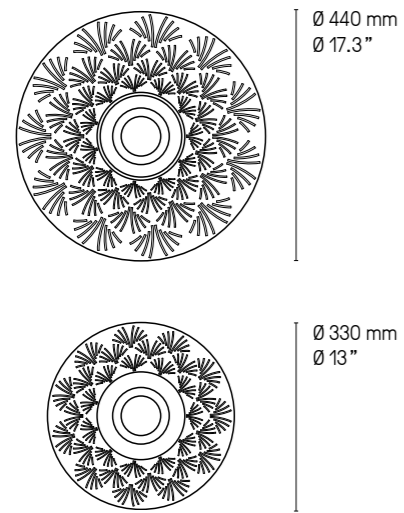

Earth Palm 330 SB/SG

Earth Turtle Ø 330 & Ø 440 mm

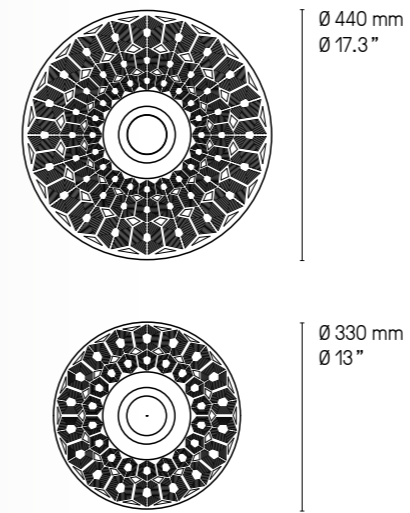

Earth Turtle 330 SG/SB



## ÉCLIPSE

Série d'appiques déclinée en deux diamètres, *Éclipse* joue de disparition entre sa dalle de led et ses deux disques de laiton. Un objet céleste qui ensoleille les architectures.



*Éclipse*, a wall light available in two diameters in which a led plate is hidden in between two brass discs. A celestial object that stuns architectures.

**Finitions**  
**Finishes** ①+②

- Laiton satiné    ● Graphite satiné    ● Nickel satiné    ● Cuivre satiné
- SB** Satin brass    **SG** Satin graphite    **SN** Satin nickel    **SC** Satin copper

Détails page 222

En standard, le petit disque au centre du produit sera toujours en finition ① polie.  
Si vous préférez une finition satinée, merci de le préciser.  
The small centered disc on the front always comes in a polished finish ① but can be in satin if specified.

**Matériaux**  
**Material** Laiton massif  
Solid Brass

**Description**  
**Features** L'applique *Éclipse* est fixe. Une fois positionnée au mur, elle ne peut pas tourner.  
Please be aware that discs are fixed and cannot be positioned in any other way.

**Source**  
**Lamping** LED intégrée 1600 lm 3 000°K    Alim. électronique intégrée    Variation (phase cut)  
Integrated LED 1600 lm 3 000°K    Integrated power supply    Dimmable (phase cut)

**Designer** Hervé Langlais

**Éclipse XL**

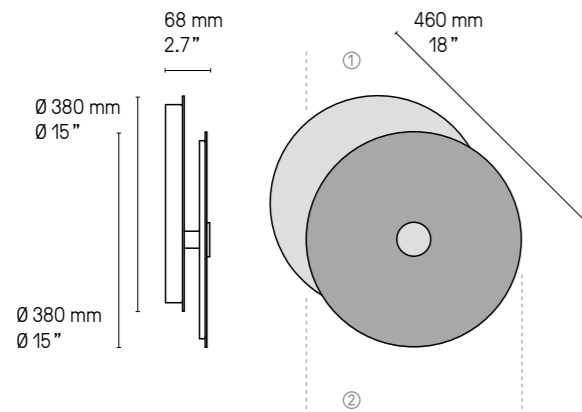

**Éclipse XS**

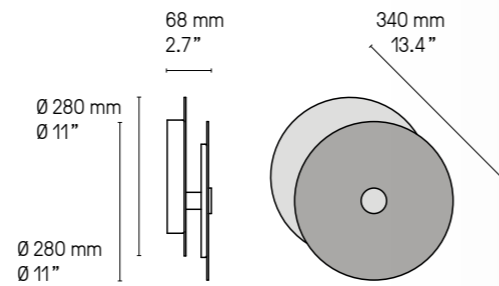

Éclipse XL SB/SG

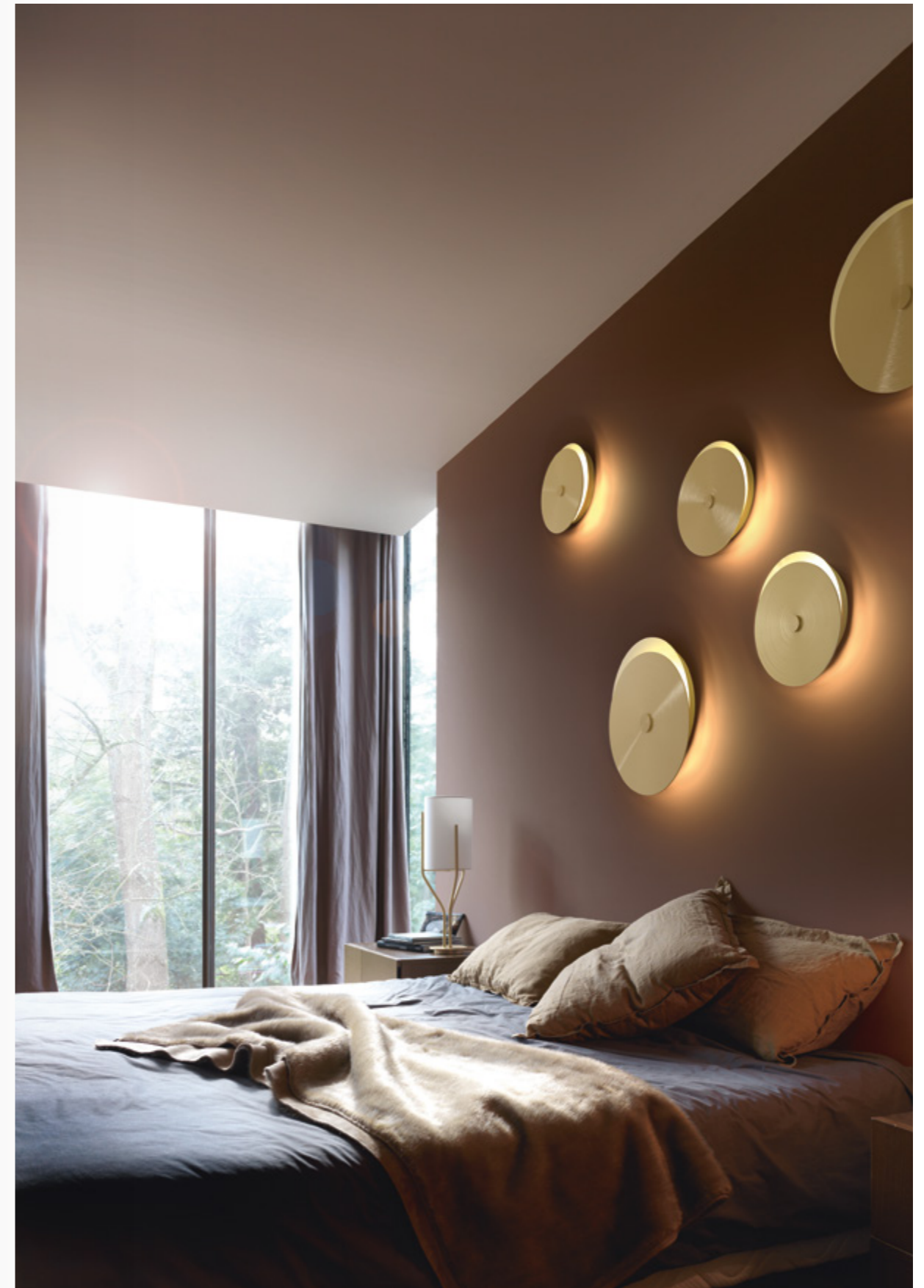

Éclipse XS + XL SB/SB



## ELLIS

Empiètement des années 30 revisité pour ce lampadaire à l'allure classique, mais aux détails résolument contemporains. Les embouts polis, qui viennent finir la ligne en bout de tube, sont personnalisables à la demande.

A step back in time for this remake of a classical 1930's floor lamp, redesigned with contemporary details. The polished tips at the end of each brass tubes are customizable on request.

**Finitions** ①+②  
**Finishes**

Détails page 222

● Laiton satiné <b>SB</b> Satin brass	● Graphite satiné <b>SG</b> Satin graphite	● Nickel satiné <b>SN</b> Satin nickel	● Cuivre satiné <b>SC</b> Satin copper
● Laiton poli <b>PB</b> Polished brass	● Graphite poli <b>PG</b> Polished graphite	● Nickel poli <b>PN</b> Polished nickel	● Cuivre poli <b>PC</b> Polished copper



**Abat-jour**  
**Lampshade**

□ Drop Paper® 100	■ Drop Paper® 101	■ Drop Paper® 103
-------------------	-------------------	-------------------

**Matériaux**  
**Material**

Laiton massif Solid Brass	Abat-jour Drop Paper® M1 Lampshade Drop Paper® M1	Câble textile noir (longueur ≈ 2 m) Black textile cable (length ≈ 79")
------------------------------	--	---

**Source**  
**Lamping**

<b>Lampadaire – Floor lamp</b>			
1 x E27 205W max. Ampoule non fournie 1 x E27 205W max. Bulb not included	Variateur à pied Foot operated dimmer	Variation* Dimming*	
1 x E26 type A 150W. Bulb not included	Foot operated switch		
<b>Lampe de table – Table lamp</b>			
1 x E27 105W max. Ampoule non fournie 1 x E27 105W max. Bulb not included	Interrupteur sur câble Cable switch		
1 x E26 type A 100W. Bulb not included	Cable switch		

**Designer**

Hervé Langlais

\* Les luminaires variables nécessitent l'utilisation d'ampoules compatibles avec la variation  
All dimmable light fixtures require the use of compatible bulbs

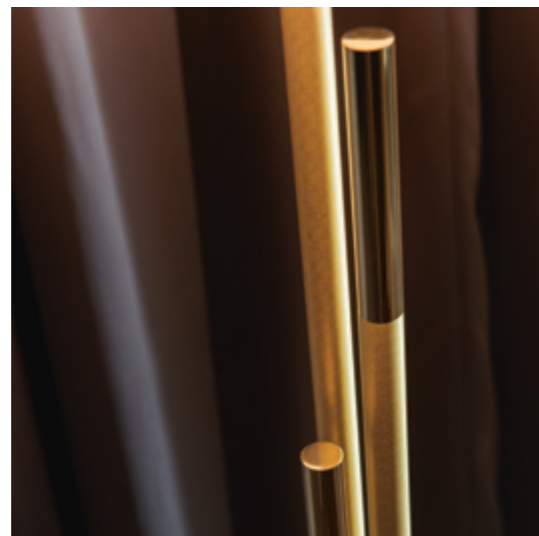

Ellis SB/PB

**Lampadaire – Floor lamp**

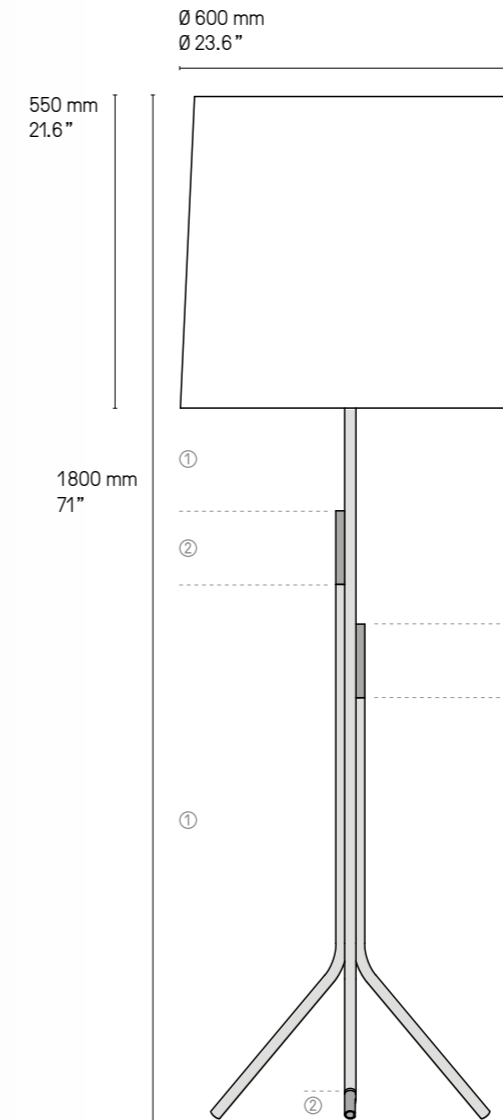

**Lampe de table – Table lamp**

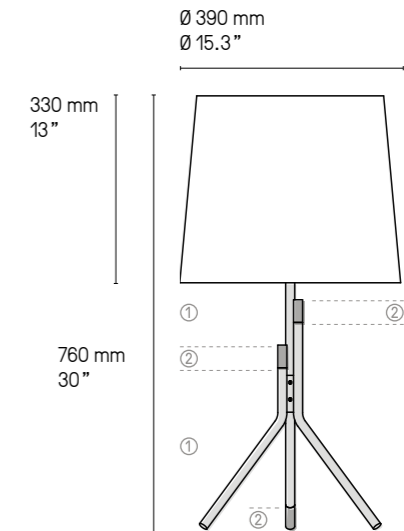

Version LED et DALI sur demande.  
LED and DALI version upon request.



## FLÉA

Collection inspirée par le célèbre artiste de jazz, les suspensions *et* appliques *Fléa* jouent des effets de lumières avec le verre et le laiton. Modulables, créez vos compositions de « trompettes » à l'envi.



A collection inspired by the iconic jazz artist, the *Fléa* pendants and wall lights play with lighting effects on the glass and the brass. Adjustable, you can arrange the “trumpets” as you wish.

**Finitions Finishes**

● Laiton satiné SB Satin brass	● Graphite satiné SG Satin graphite	● Nickel satiné SN Satin nickel	● Cuivre satiné SC Satin copper
-----------------------------------	--	------------------------------------	------------------------------------

Détails page 222

**Câble Cable**

■ Tissu noir Black textile	■ Tissu or Gold textile
-------------------------------	----------------------------

La longueur standard des câbles est de 2 mètres pour les suspensions et 15 cm pour les appliques mais elle peut être diminuée à l'installation. Autres longueurs sur demande.  
The standard height of the cables is 2 meters (79") for a pendant and 150 mm (5.9") for a wall light it can be adjusted to less during installation. Custom heights available upon request.

**Matériaux Material**

Laiton massif Solid Brass	Verrerie soufflée bouche Mouth-blown glass	Câble textile Textile cable
------------------------------	---	--------------------------------

**Source Lamping**

G9 LED 5W max. non fournie G9 LED 5W max. not included	Not available for 110V	Variation* Dimming*
---	------------------------	------------------------

**Designer** Émilie Cathelineau

\* Les luminaires variables nécessitent l'utilisation d'ampoules compatibles avec la variation  
All dimmable light fixtures require the use of compatible bulbs

**Applique – Wall light**

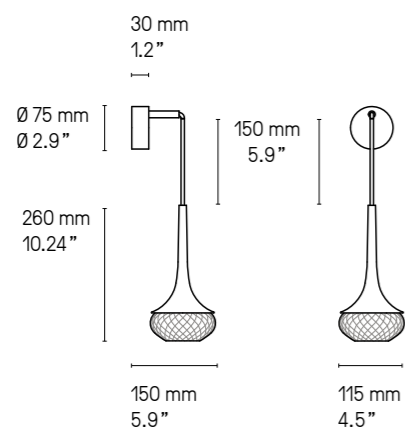

Applique – Wall light Fléa SB

**Suspension – Pendant**

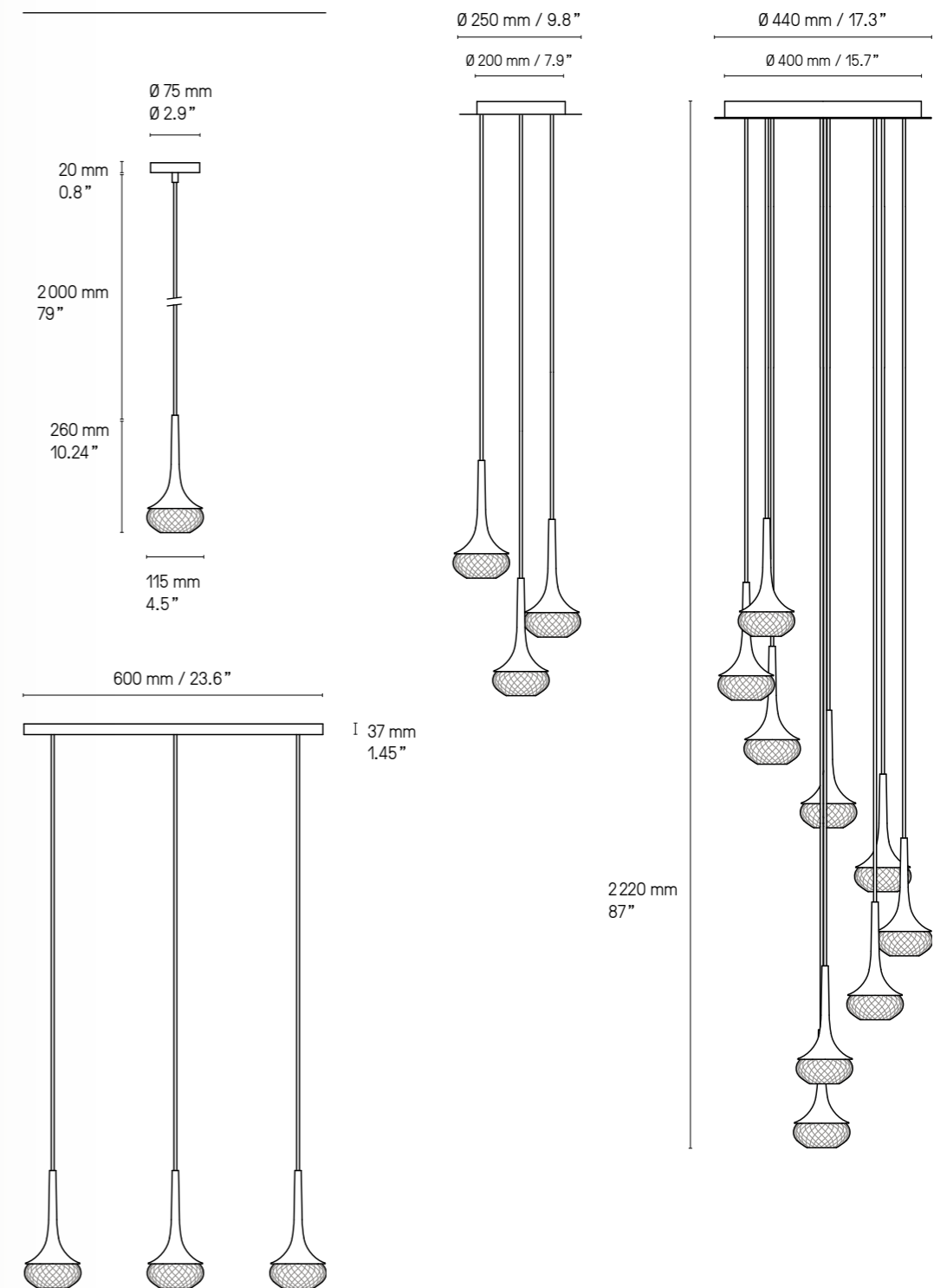

Il est possible de rassembler plusieurs suspensions sur un seul pavillon, circulaire ou rectangulaire. La version rectangulaire peut être adaptée à n'importe quelle longueur. La version circulaire a un diamètre maximum indiqué sur les croquis ci-dessus. Pour plus de renseignements, veuillez nous contacter.

It is possible to cluster several pendants from one single canopy, either rectangular or circular. The rectangular canopy can be custom-made into any size to suit your requirements. As for the circular canopy, available sizes are illustrated above. Please contact us for further information.







## GAMMA

*Gamma* est un système graphique et versatile. C'est à partir de tubes métalliques et de cylindres blancs opalins, multipliés, que s'agence ainsi toute une gamme de luminaires



*Gamma* is a striking and versatile lighting system. The design of this collection is based on the multiplication of metal tubes and opal white luminous cylinders, assembled like a chain.

**Finitions  
Finishes**

Détails page 222

● Laiton satiné SB Satin brass	● Graphite satiné SG Satin graphite	● Nickel satiné SN Satin nickel	● Cuivre satiné SC Satin copper
● Laiton poli PB Polished brass	● Graphite poli PG Polished graphite	● Nickel poli PN Polished nickel	● Cuivre poli PC Polished copper

**Matériaux  
Material**

<b>Tous – All</b> Laiton massif Solid Brass Diffuseur polycarbonate blanc White Polycarbonate diffuser	<b>Suspension – Pendant</b> Câble métallique et câble électrique transparent Metal cable and transparent electric cable  <i>La longueur standard des câbles est de 2 mètres mais elle peut être diminuée à l'installation. The standard height of the cables is 2 meters (79") but can be adjusted to less during installation.</i>
--	---

**Source  
Lamping**

<b>Applique – Wall light</b>			
LED intégrée	480 lm	2700°K	Alimentation 24V int. intégrée
Integrated LED	480 lm	2700°K	Int. power supply 24V included
			Variable (phase cut) Dimmable (phase cut)
<b>Suspensions – Pendant lights</b>			
<b>Gamma L 5</b>			
LED intégrée	580 lm	2700°K	Alim. 24V int. dans le pavillon
Integrated LED	580 lm	2700°K	Int. power supply 24V incl. in canopy
			Variable (phase cut) Dimmable (phase cut)
<b>Gamma L 19</b>			
LED intégrée	1730 lm	2700°K	Alim. 24V int. dans le pavillon
Integrated LED	1730 lm	2700°K	Int. power supply 24V incl. in canopy
			Variable (phase cut) Dimmable (phase cut)
<b>Gamma R 40</b>			
LED intégrée	3740 lm	2700°K	Alim. 24V int. dans le pavillon
Integrated LED	3740 lm	2700°K	Int. power supply 24V incl. in canopy
			Variable (phase cut) Dimmable (phase cut)
<b>Gamma R 58</b>			
LED intégrée	5180 lm	2700°K	Alim. 24V int. dans le pavillon
Integrated LED	5180 lm	2700°K	Int. power supply 24V incl. in canopy
			Variable (phase cut) Dimmable (phase cut)

**Designer**

Sylvain Willenz

**Applique – Wall light Gamma**

1 x Tube laiton - 2 x Tubes diffuseurs  
1 x Brass tube - 2 x Diffuser tubes

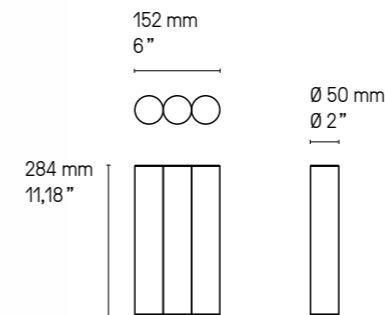

Gamma SB

Gamma SC



Gamma SN



Gamma SG

Retrouvez les variantes salle de bain (IP44) de ces modèles p.204  
You will find the bathroom variants (IP44) of these designs p.204

**Suspension – Pendant Gamma L 5**

3 x Tubes laiton - 2 x Tubes diffuseurs  
 3 x Brass tubes - 2 x Diffuser tubes

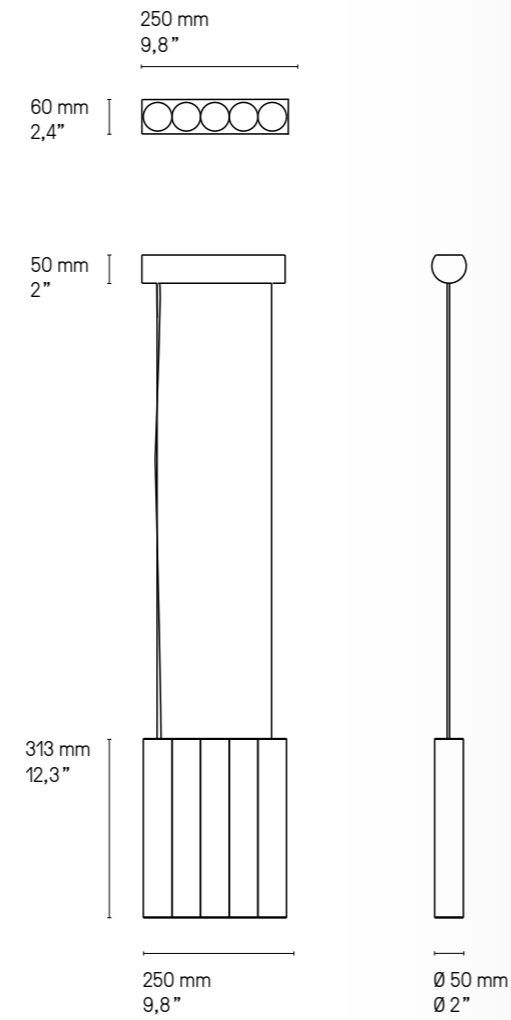

**Suspension – Pendant Gamma L 19**

13 x Tubes laiton - 6 x Tubes diffuseurs  
 13 x Brass tubes - 6 x Diffuser tubes

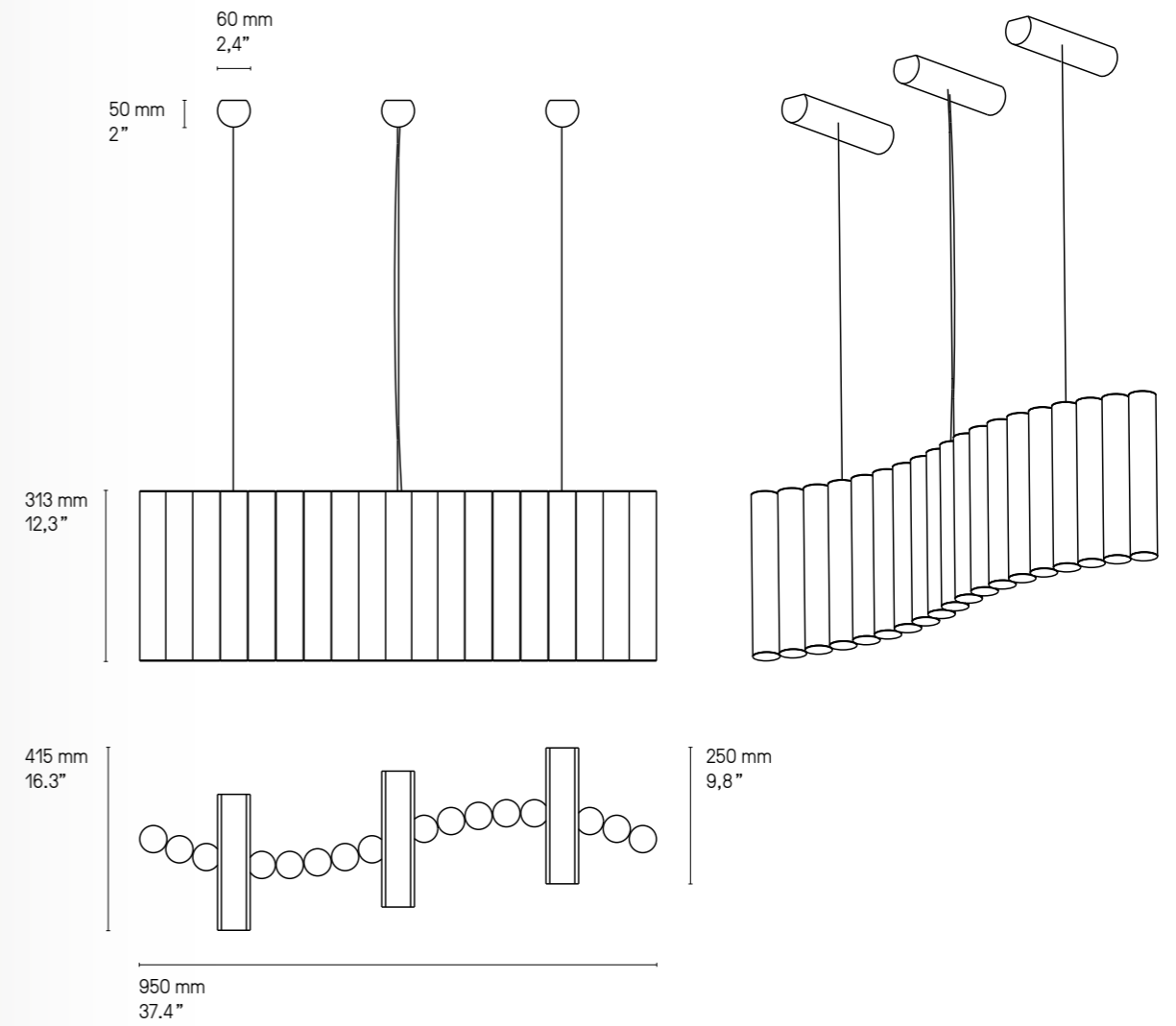

Gamma L 19 SB

**Suspension – Pendant Gamma R 40**

27 x Tubes laiton - 13 x Tubes diffuseurs  
 27 x Brass tubes - 13 x Diffuser tubes

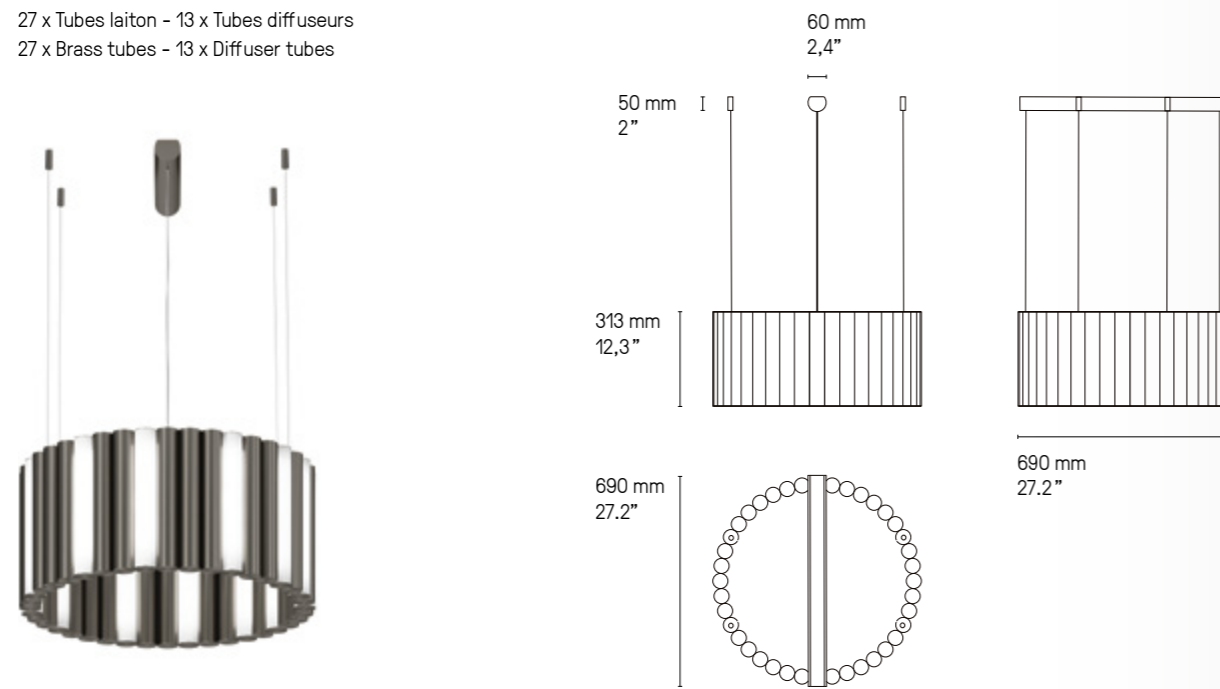

**Suspension – Pendant Gamma R 58**

40 x Tubes laiton - 18 x Tubes diffuseurs  
 40 x Brass tubes - 18 x Diffuser tubes

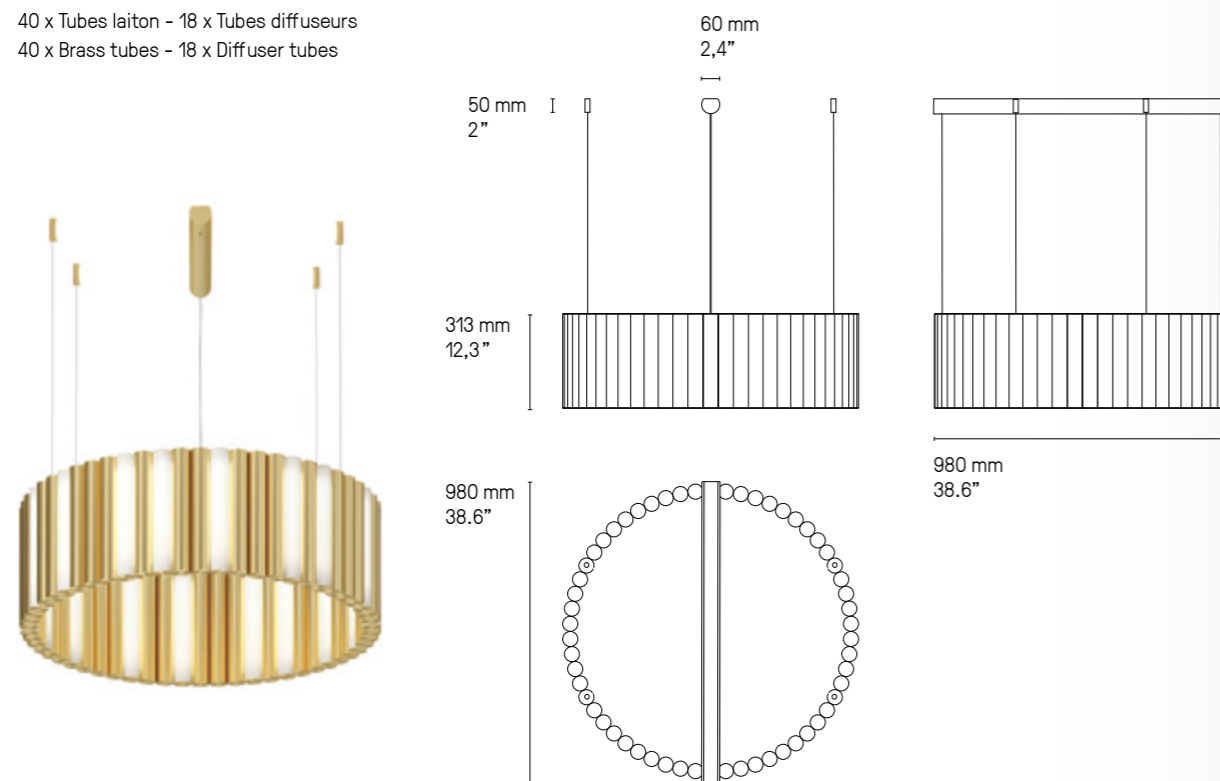

Gamma R 40 SB



## JANED

Tel un petit phare de voiture ancienne, la coupelle de *Janed* vient refléter la lumière de la sphère opaline.



Like a small headlight from an old car, *Janed's* cup reflects the light of the opaline sphere

**Finitions**  
**Finishes** ① + ②

Détails page 222

● Laiton satiné SB Satin brass	● Graphite satiné SG Satin graphite	● Nickel satiné SN Satin nickel	● Cuivre satiné SC Satin copper
● Laiton poli PB Polished brass	● Graphite poli PG Polished graphite	● Nickel poli PN Polished nickel	● Cuivre poli PC Polished copper

<b>Matériaux</b> <b>Material</b>	<b>Tous – All</b> Laiton massif Solid Brass	<b>Tous – All</b> Verre triplex opale Opal triplex glass	<b>Janed 140 Cable</b> Câble textile noir (longueur ≈ 2 m) Black textile cable (length ≈ 79")
-------------------------------------	---	--	---

<b>Source</b> <b>Lamping</b>	<b>Appliques – Wall mounted lights</b>	
	<b>Janed 120 &amp; 140 Simple</b> G9 LED 5W max. non fournie G9 LED 5W max. not included	Variable* Dimmable*
	<b>Janed 140 Tirette/Cord</b> G9 LED 5W max. non fournie G9 LED 5W max. not included	Interrupteur par tirette Pull cord switch
	<b>Janed 140 Cable</b> G9 LED 5W max. non fournie G9 LED 5W max. not included	Interrupteur sur le câble Cable switch
	<b>Lampe de table – Table lamp</b> G9 LED 5W max. non fournie G9 LED 5W max. not included	Interrupteur sur le câble Cable switch

**Designer** Émilie Cathelineau

\* Les luminaires variables nécessitent l'utilisation d'ampoules compatibles avec la variation  
All dimmable light fixtures require the use of compatible bulbs

**US Version**  
**fitted plate to cover**  
**outlet power box**

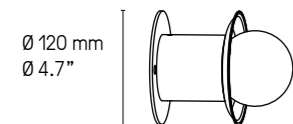

Applique – Wall mounted light  
Janed 140 Simple SB

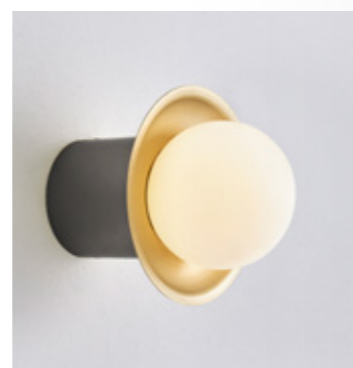

Applique – Wall mounted light  
Janed 140 Simple SB/SG

**Janed Appliques – Wall lights**

**JANED 120 Simple**

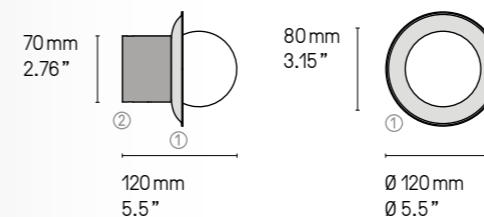

**JANED 140 Simple**

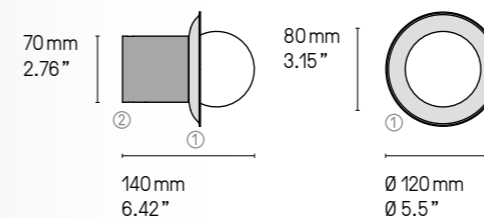

**JANED 140 Tirette/Cord**

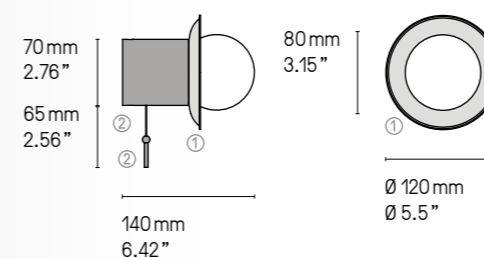

**JANED 140 Cable**

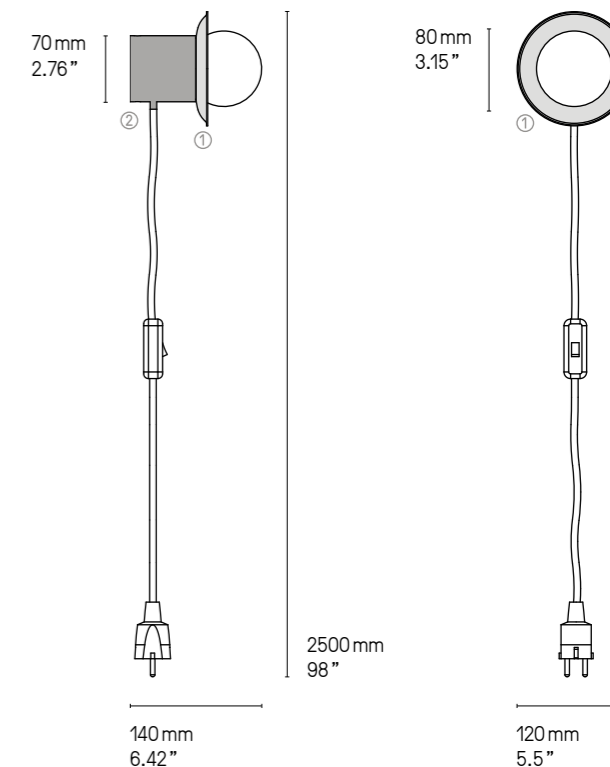

La longueur des câbles est réglable à l'installation.  
The height of the cables can be adjusted during installation.

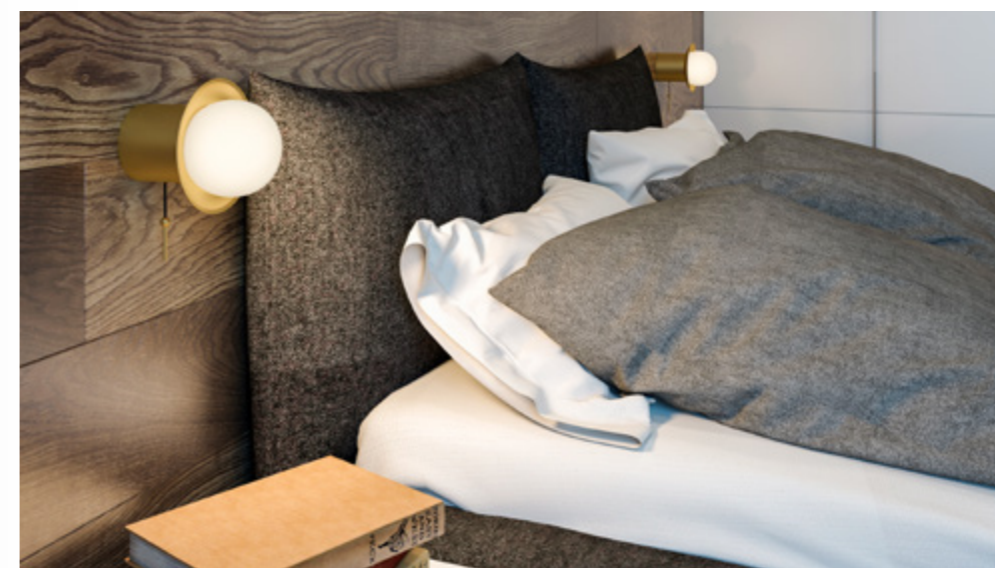

Applique – Wall mounted light Janed 140 Tirette/Cord SB



Applique – Wall mounted light  
Janed 140 Simple SN

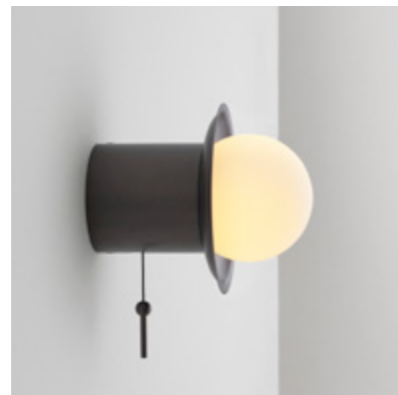

Applique – Wall mounted light  
Janed 140 Tirette/Cord SG



Applique – Wall mounted light  
Janed 140 Cable PN

Longueurs sur mesure possibles.  
Custom dimensions available upon request.



Appliques – Wall mounted lights Janed 120 Simple SG



**Janed Lampe de table – Table lamp**

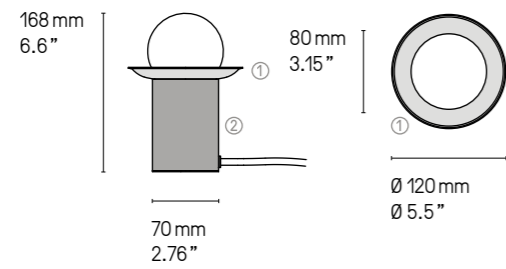

Lampe de table – Table lamp Janed SG



Lampe de table – Table lamp Janed SG



## LINK

Sobre et minimaliste, la collection *Link* encadre la lumière. Selon l'orientation du luminaire, la ligne épurée s'inscrit dans l'espace vertical et horizontal.



Simple and minimalist, the *Link* collection frames the light. Depending on the position of the light, the refined line can be fitted vertically or horizontally.



## Appliques – Wall lights

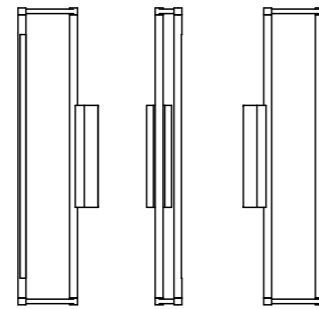
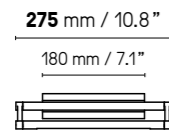
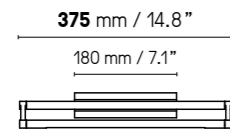
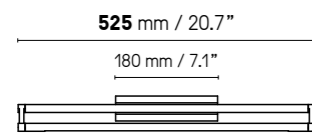
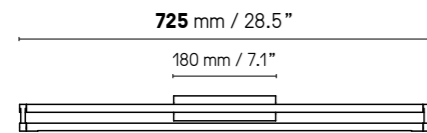
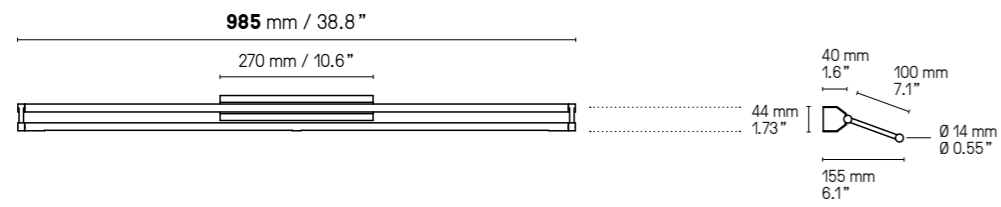

Link peut être installée horizontalement ou verticalement.  
Link can be placed both horizontally or vertically on the wall.

**UL Version**  
fitted plate to cover outlet power box

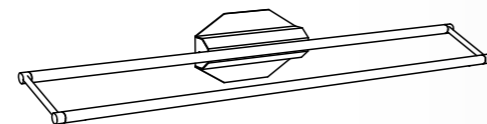
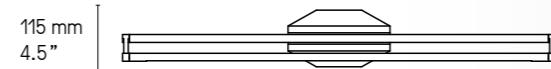

Longueurs sur mesure possibles.  
Custom dimensions available upon request.

### Description Features

Cette applique est réglable sur 2 axes. Le tube avant, dans lequel se trouve la LED tourne afin de diriger la lumière dans n'importe quelle direction. L'ensemble formant un cadre peut également pivoter de haut en bas si l'applique est installée à l'horizontale, ou de gauche à droite si elle est installée à la verticale.

The wall light is adjustable in 2 ways. The front LED bar can be spinned around to diffuse the light in any direction and the rectangular frame can be flipped up and down when the light is positioned horizontally, and side to side when positioned vertically.



Applique – Wall light Link 985 SB

Liseuses murales – Reading wall lights

Longueurs sur mesure possibles.  
 Retrouvez les variantes salle de bain (IP44) de ces modèles p.206  
 Custom dimensions available upon request.  
 You will find the bathroom variants (IP44) of these designs p.206

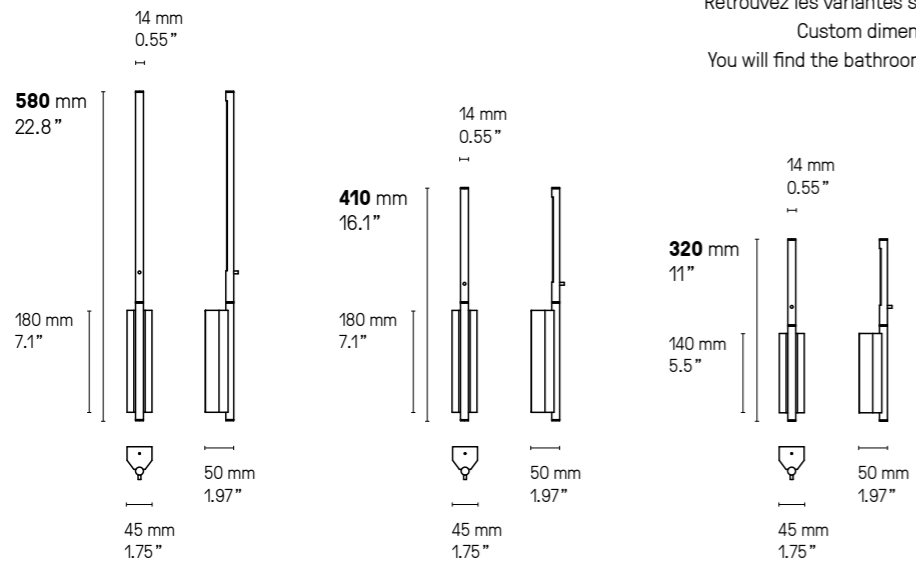

Interrupteur en option  
 Switch in option

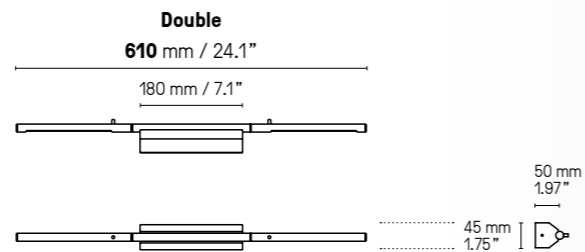
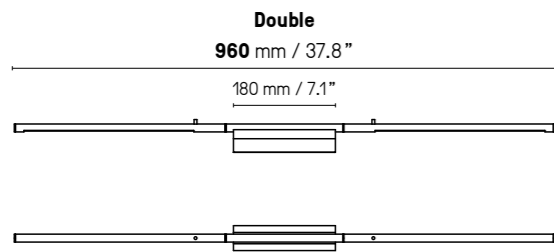
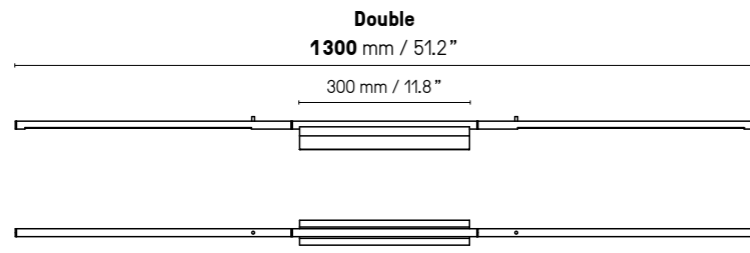

Le tube avant, dans lequel se trouve la LED, tourne afin de diriger la lumière dans n'importe quelle direction  
 The front LED bar can be spinned around to diffuse the light in any direction



UL Version  
 fitted plate  
 to cover outlet  
 power box

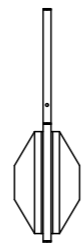

115 mm  
 4.5"





**Lampadaire – Floor lamp**

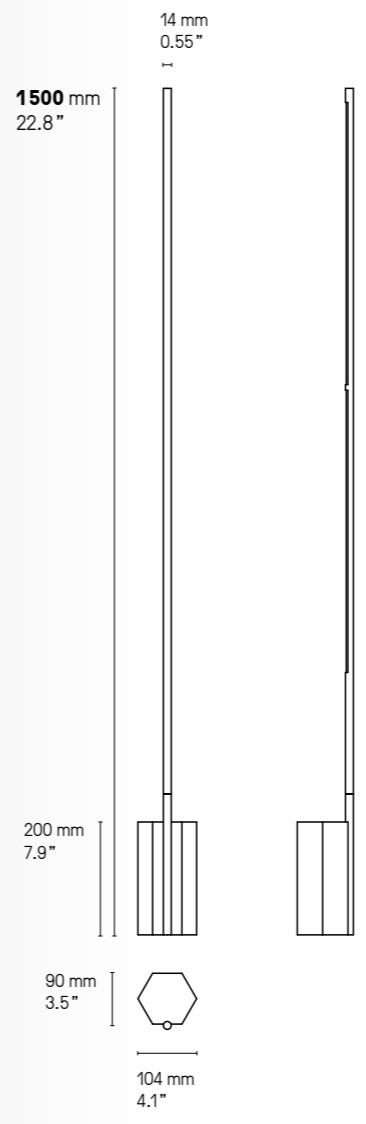

Lampadaire – Floor lamp Link SB

**Lampe de table – Table lamp**

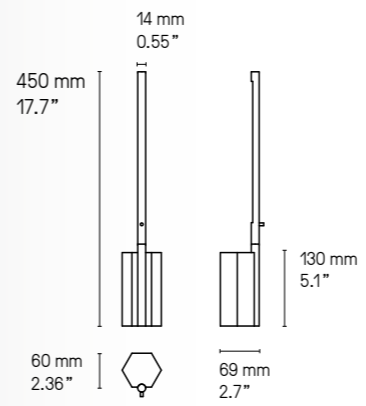

Lampe de table – Table lamp Link SB

Suspension – Pendant

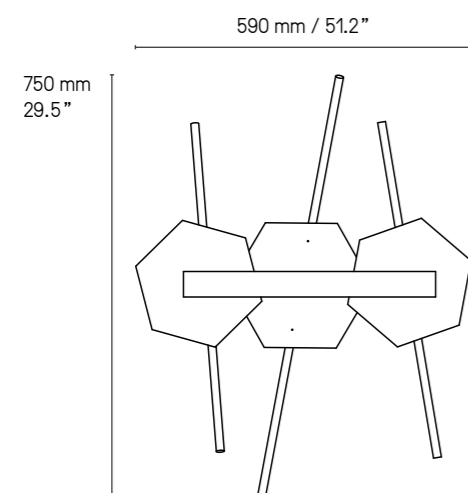

Suspensions – Pendant Link SB

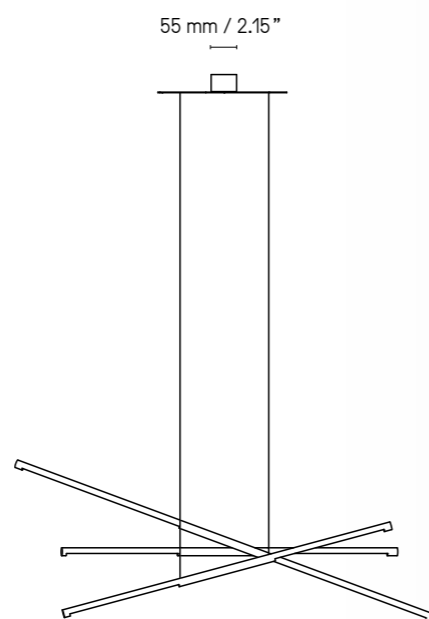
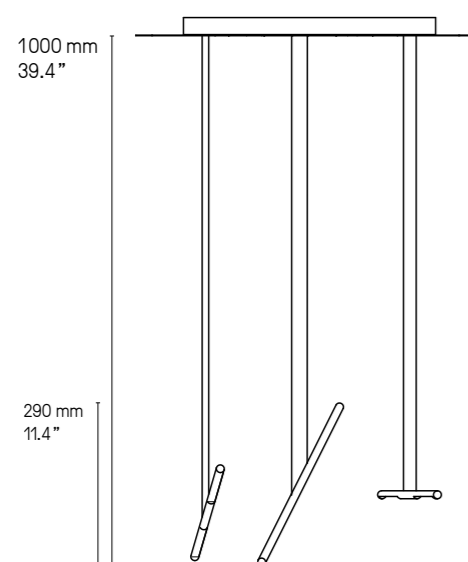

La longueur des câbles est réglable à l'installation.  
The height of the cables can be adjusted during installation.



Suspensions – Pendant Link SG



## LOUIS

Collection inspirée par le célèbre artiste de jazz, les suspensions *Louis* jouent des effets de lumières avec le verre et le laiton. Modulables, créez vos compositions de « trompettes » à l'envi.



A collection inspired by the iconic jazz artist, the *Louis* pendants play with lighting effects on the glass and the brass. Adjustable, you can arrange the “trumpets” as you wish.



**Finitions**  
**Finishes**

- Laiton satiné / SB Satin brass
- Graphite satiné / SG Satin graphite
- Nickel satiné / SN Satin nickel
- Cuivre satiné / SC Satin copper

Détails page 222

**Nuances du verre**  
**Glass colors**

- Opale / Opal
- Opale et écaille / Opal and patterned
- Claire et écaille / Clear and patterned

**Câble**  
**Cable**

- Tissu noir / Black textile
  - Tissu or / Gold textile
- La longueur standard des câbles est de 2 mètres mais elle peut être diminuée à l'installation.  
 The standard height of the cables is 2 meters (79") but can be adjusted to less during installation.*

**Matériaux**  
**Material**

- Laiton massif / Solid Brass
- Verrerie soufflée bouche / Mouth-blown glass
- Câble textile / Textile cable

**Source**  
**Lamping**

- LED intégrée 1500 lm 2700°K / Integrated LED 1500 lm 2700°K
- Alim. électr. intégrée dans le pavillon / Int. power supply included in canopy
- Variation (phase cut) / Dimmable (phase cut). USA, please, contact us



**Designer**

Émilie Cathelineau

**Louis XS**

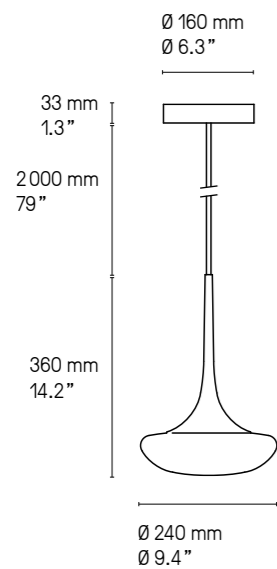

**Louis XL**

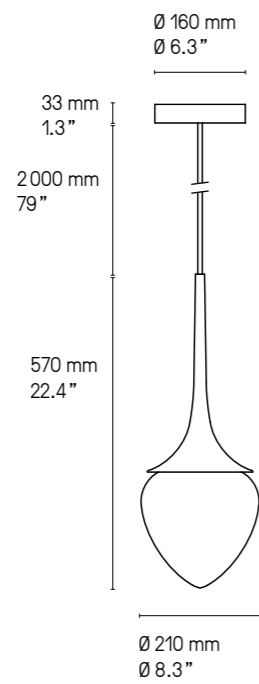

500 mm / 19.7"

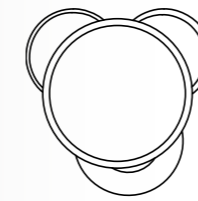

Ø 340 mm / 13.4"  
 Ø 300 mm / 11.8"

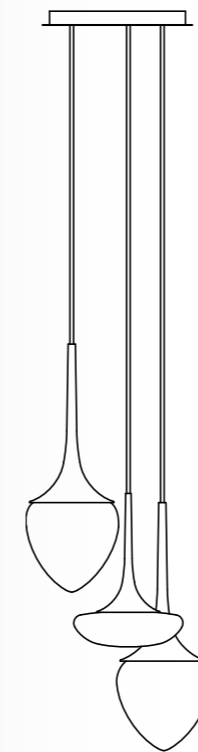

580 mm / 22.8"

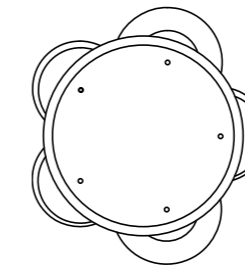

Ø 440 mm / 17.3"  
 Ø 400 mm / 15.7"

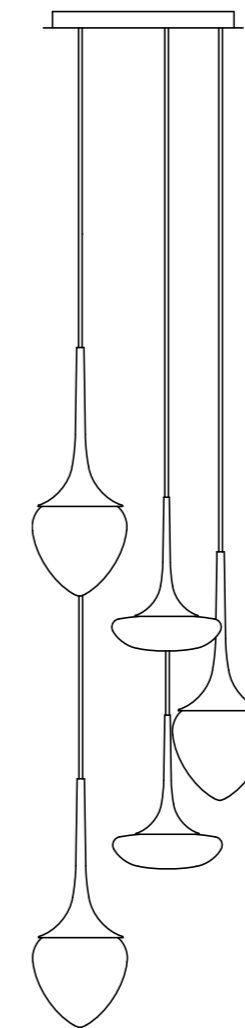

1100 mm / 43.3"

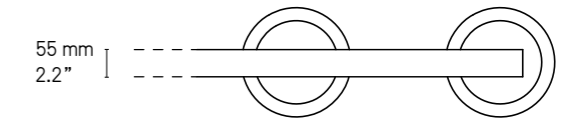

1000 mm / 39.4"

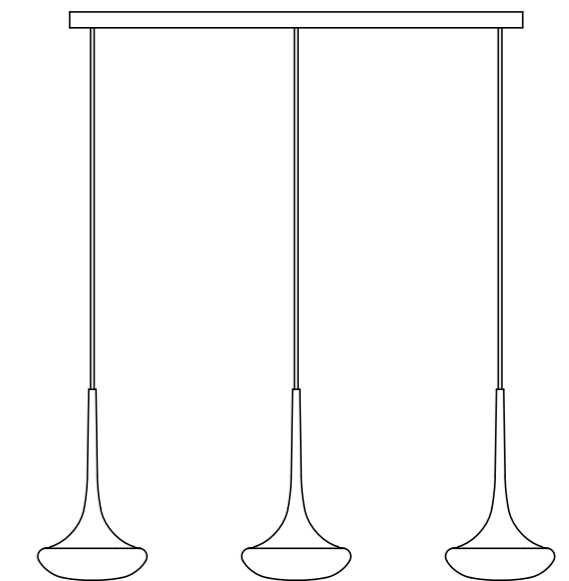

Il est possible de rassembler plusieurs suspensions sur un seul pavillon, circulaire ou rectangulaire. La version rectangulaire peut être adaptée à n'importe quelle longueur. La version circulaire a un diamètre maximum indiqué sur les croquis ci-dessus. Pour plus de renseignements, veuillez nous contacter.

It is possible to cluster several pendants from one single canopy, either rectangular or circular. The rectangular canopy can be custom-made into any size to suit your requirements. As for the circular canopy, available sizes are illustrated above. Please contact us for further information.



Louis XS SG Opale écaille – Opal patterned



Louis XL SB Opale écaille – Opal patterned

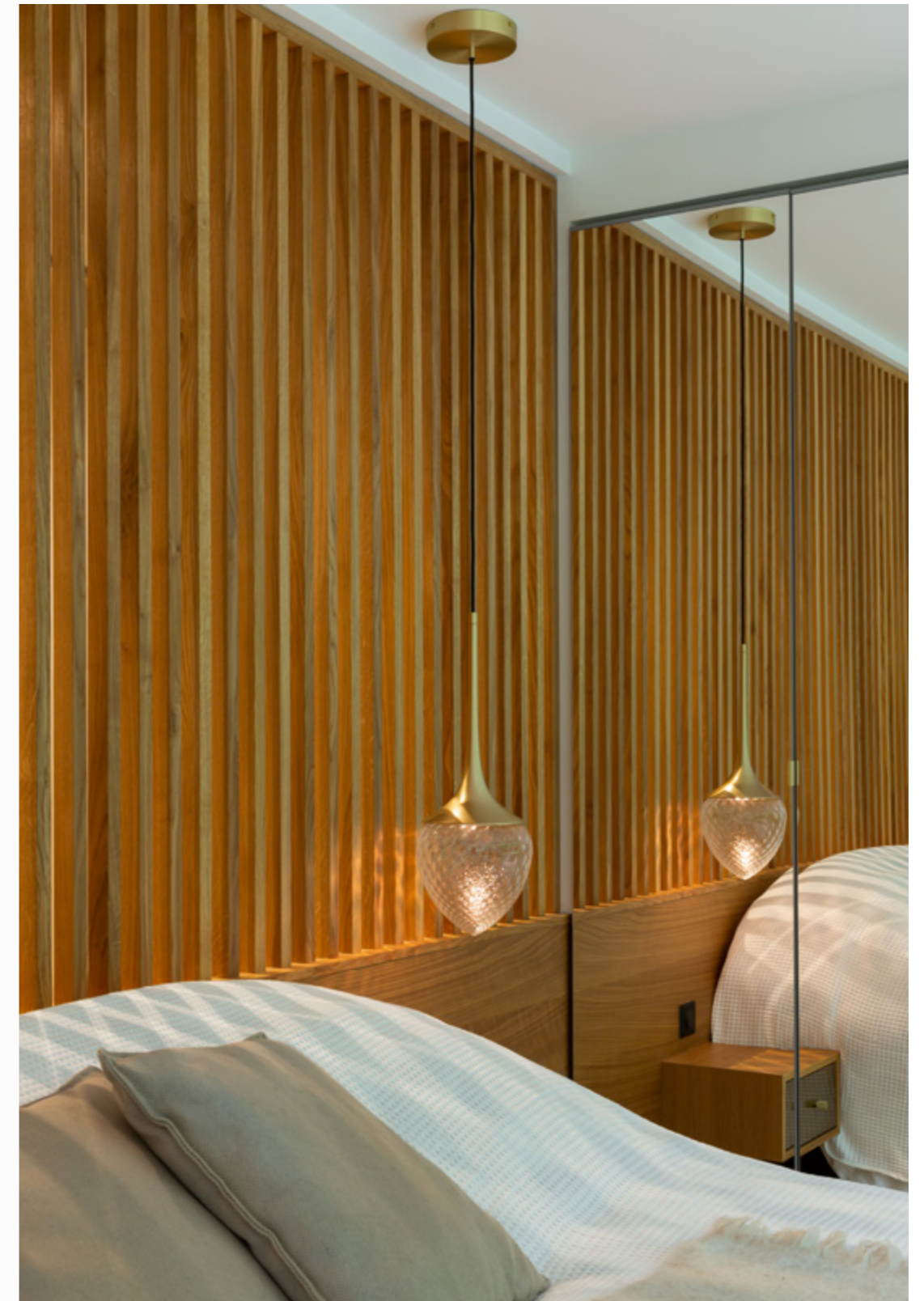

Louis XL SB Écaille – Patterned



## NACHO

Inspiré de peintures, et tout droit sorti du langage graphique imaginaire de Sylvain Willenz, *Nacho* rassemble sur une même ligne divers éléments sculpturaux et lumineux.



Inspired by paintings, and straight out of the imaginary graphic language of Sylvain Willenz, *Nacho* gathers along one single line, various sculptural and lighting elements.

**Finitions** ①+②+③  
**Finishes** ①+②+③

● Laiton satiné  
**SB** Satin brass

● Graphite satiné  
**SG** Satin graphite

● Nickel satiné  
**SN** Satin nickel

● Cuivre satiné  
**SC** Satin copper

Détails page 222

**Matériaux**  
**Material**

Laiton massif  
 Solid Brass

Verre opale  
 Opal glass

Diffuseur polycarbonate satiné  
 Satin Polycarbonate diffuser

**Source Lamping**

**Nacho 1300**  
 Ruban LED intégré (840 lm, 2700°K) + Non incluses : G4 LED 3W max. et 2 x GU 5.3 LED 6W max.  
 Alimentations 24V et 12V intégrées dans le pavillon Variable (phase cut)  
 Integrated strip LED (840 lm, 2700°K) + Not included: G4 LED 3W max. and 2 x GU 5.3 LED 6W max.  
 Internal power supplies 24V and 12V included in canopy Dimmable (phase cut)

**Nacho 750**  
 Ruban LED intégré (670 lm, 2700°K) + Non incluses : 2 x G4 LED 3W max.  
 Alimentations 24V et 12V intégrées dans le pavillon Variable (phase cut)  
 Integrated strip LED (670 lm, 2700°K) + Not included: 2 x G4 LED 3W max.  
 Internal power supplies 24V and 12V included in canopy Dimmable (phase cut)

**Designer** Sylvain Willenz

**Nacho 750**

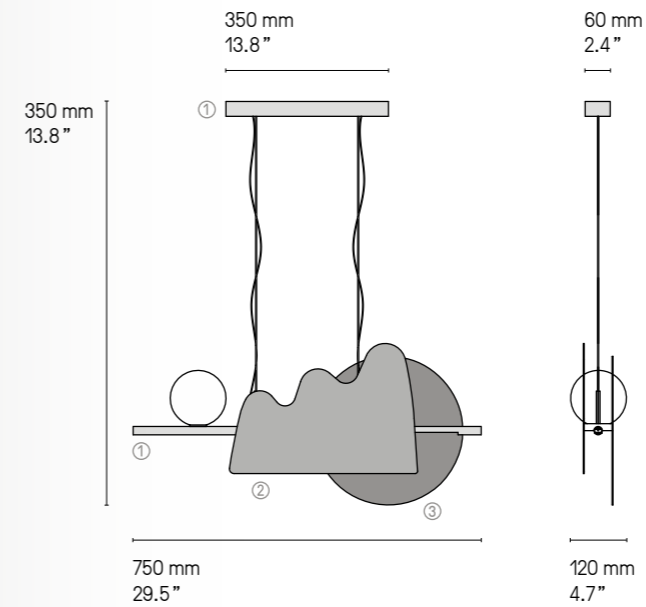

Nacho 750 SG/SG/SB

**Nacho 1300**

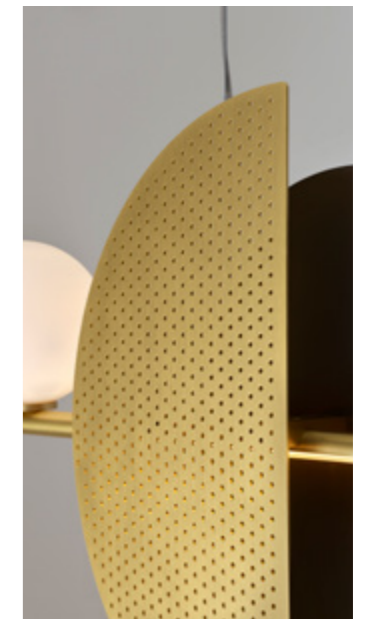
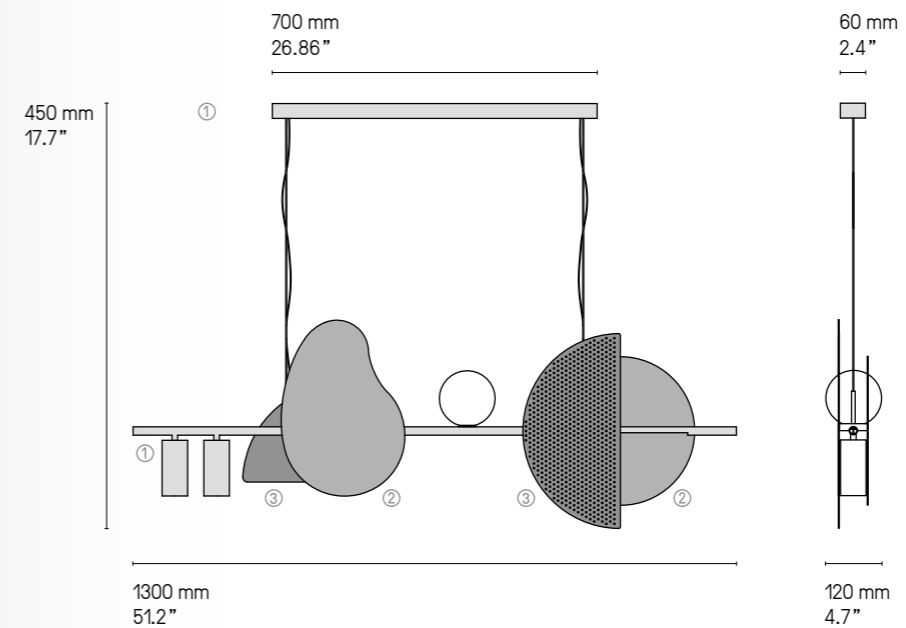

Nacho 1300 SB/SG/SB



Nacho 1300 SB/SB/SG

**US Version**  
 fitted plate to cover  
 outlet power box

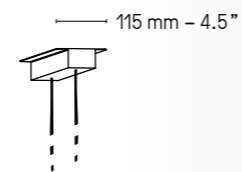

La longueur des câbles est réglable à l'installation.  
 The height of the cables can be adjusted during installation.



## RING

À la fois inspirée des années 60 et intemporelle, la suspension bicolore *Ring* est montée d'une pièce « bijou » en laiton poli. Définissez ses tonalités selon l'effet décoratif recherché.



At once inspired by the 60's but also timeless, the two-toned pendant *Ring* is assembled with an imitated polished brass "jewel". Characterize its shades in accordance to the style you are looking for.

**Finitions Finishes**





Détails page 222

**Bicolore – Bicolor** ①/②

 Graphite satiné	 Laiton satiné	 Nickel satiné	 Graphite satiné	 Nickel satiné
<b>SG</b> / Laiton satiné	<b>SB</b> / Graphite satiné	<b>SN</b> / Nickel satiné	<b>SG</b> / Nickel satiné	<b>SN</b> / Graphite satiné
<b>SB</b> / Satin graphite / Satin brass	<b>SG</b> / Satin brass / Satin graphite	<b>SN</b> / Satin graphite / Satin nickel	<b>SG</b> / Satin nickel	<b>SN</b> / Satin nickel / Satin graphite

**Finitions Finishes**

**Uni – Unicolor**

 Laiton satiné	 Graphite satiné	 Nickel satiné	 Cuivre satiné
<b>SB</b> / Satin brass	<b>SG</b> / Satin graphite	<b>SN</b> / Satin nickel	<b>SC</b> / Satin copper

**Matériaux Material**

Laiton massif Solid Brass	Diffuseur en polycarbonate Polycarbonate diffuser
------------------------------	--

**Description Features**

Le modèle standard n'a pas de câble. Il est fixe sur un tube de 300 mm de long, ce qui donne une hauteur totale de 440 mm. Si vous souhaitez une hauteur supérieure à 440 mm, il est possible de réaliser une version « sur câble ». La longueur standard des câbles est de 2 mètres mais elle peut être diminuée à l'installation.

The standard *Ring* light does not come with a cable but only with a 300mm (11,8") brass stem with a total drop of 440 mm (17,3"). For lengths over 440 mm (17,3") an adjustable transparent cable is added between the brass stem and the canopy in a standard length of 2 meters (79") and can be adjusted to less during installation.

**Source Lamping**

2 modules de LEDs intégrées : 2 x 1000lm / 2700°K  
Diffusion de la lumière directe et indirecte

Alim. électronique intégrée dans le pavillon  
Variation. Veuillez nous contacter

2 integrated LEDs : 2 x 1000lm / 2700°K  
Diffuses light from the top and the bottom

Integrated power supply in canopy  
Dimming. Please, contact us



**Designer**

Émilie Cathelineau



Ring SG/SB

**Version fixe – Stem version**

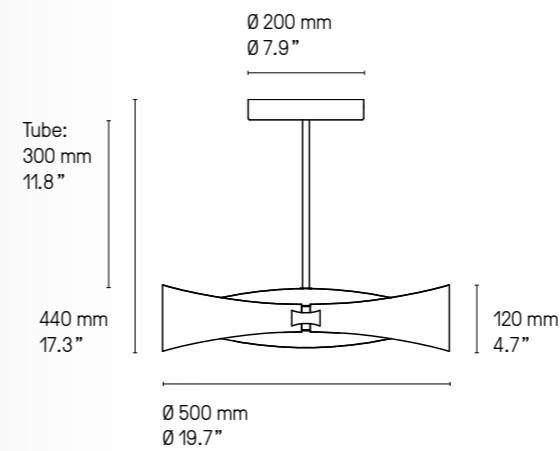

**Version câble – Cable version**

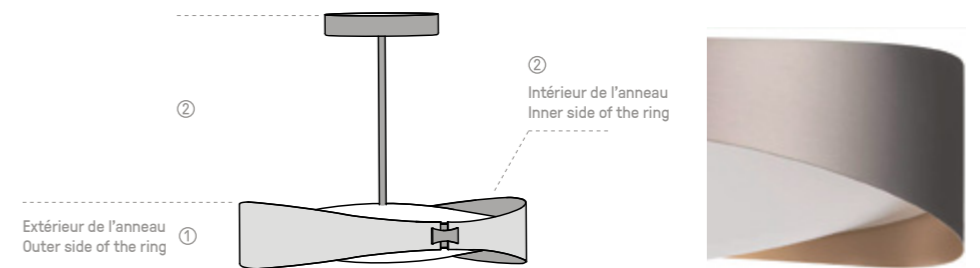
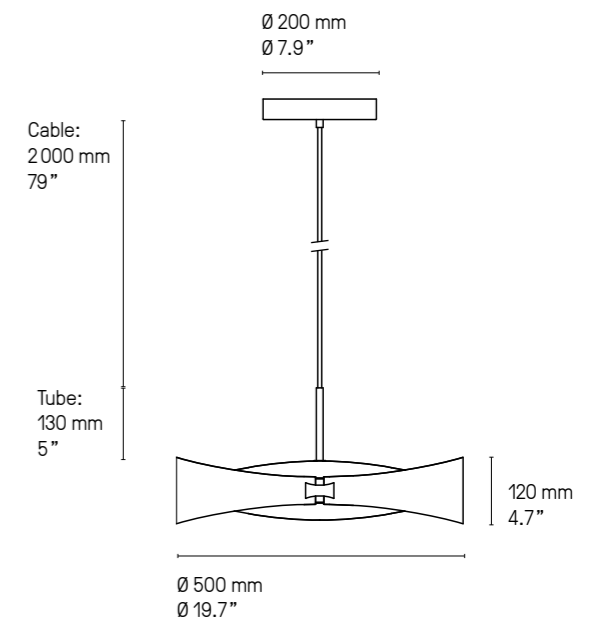

Ring SG/SB



En standard, les 2 « bijoux » sur le côté du produit sont en finition ② polie. Si vous préférez une finition satinée, merci de le préciser.

The 2 small brass parts on each side of the light always come in a polished ② finish but can be in satin if specified.



## SATURNE

La sphère lumineuse est ici prétexte au voyage dans le système solaire. Munie d'un anneau en laiton orientable, la suspension *Saturne* devient le reflet de votre vision du cosmos.



For this particular light, the luminous sphere is a representation of the solar system. Provided with a rotating brass ring, the *Saturne* pendant becomes your vision of the cosmos.

**Finitions**  
**Finishes**

- Laiton satiné
- Graphite satiné
- Nickel satiné
- Cuivre satiné
- SB** Satin brass
- SG** Satin graphite
- SN** Satin nickel
- SC** Satin copper

Détails page 222

**Matériaux**  
**Material**

- Laiton massif
- Verrerie opale soufflée bouche
- Câble textile
- Solid Brass
- Opal mouth-blown glass
- Textile cable

**Câble**  
**Cable**

- Tissu noir
  - Tissu or
  - Black textile
  - Gold textile
- La longueur standard des câbles est de 2 mètres mais elle peut être diminuée à l'installation.  
 The standard height of the cables is 2 meters (79") but can be adjusted to less during installation.*

**Source**  
**Lamping**

- XL**
- |                |         |        |                                    |   |
|----------------|---------|--------|------------------------------------|---|
| LED intégrée   | 1500 lm | 2700°K | Alimentation int. dans le pavillon | Variation (phase cut)                         |
| Integrated LED | 1500 lm | 2700°K | Int. power supply incl. in canopy  | Dimmable (phase cut). USA, please, contact us |
- XS**
- |                |        |        |                                    |                                       |
|----------------|--------|--------|------------------------------------|---------------------------------------|
| LED intégrée   | 800 lm | 2700°K | Alimentation int. dans le pavillon | Variation (phase cut)                 |
| Integrated LED | 800 lm | 2700°K | Int. power supply incl. in canopy  | Dimmable (phase cut), except for 110V |



**Designer** Hervé Langlais

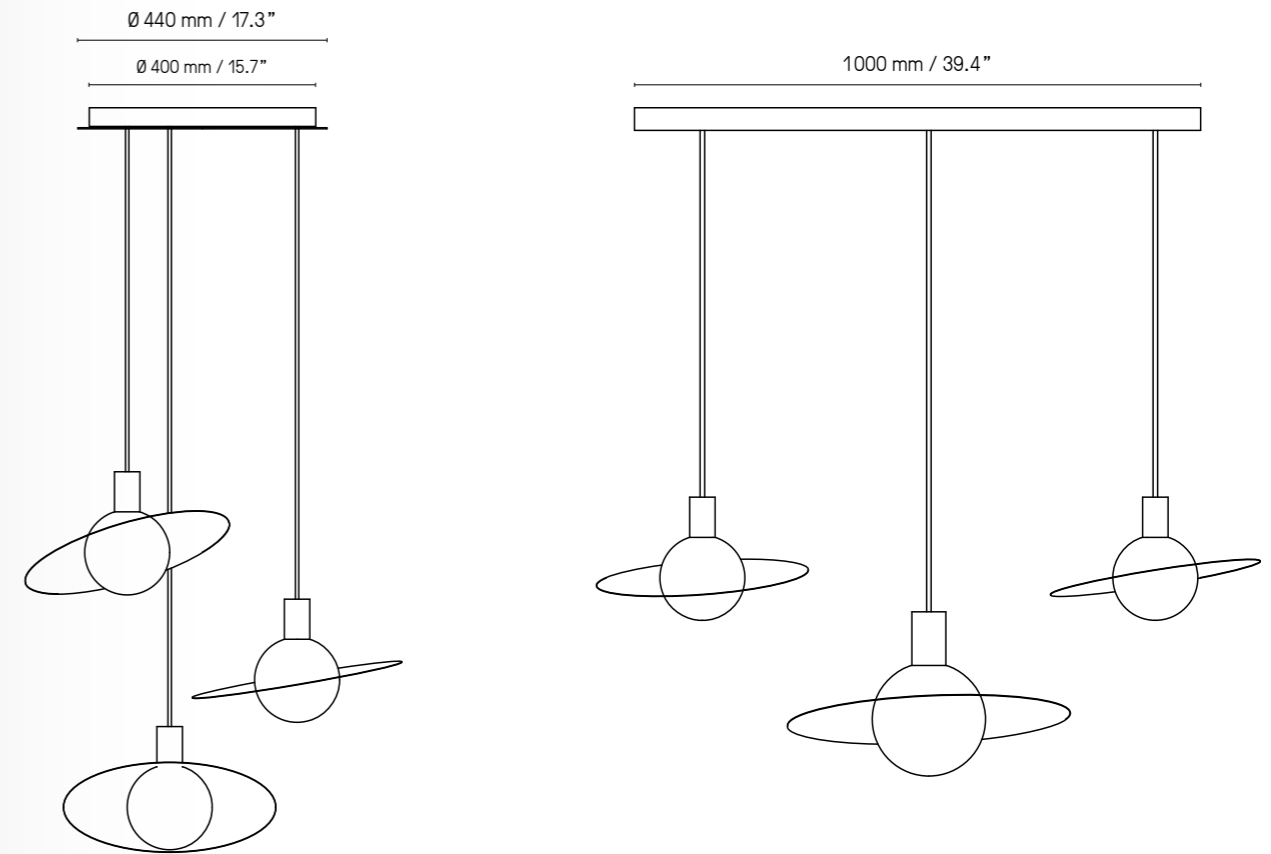

**Saturne XL**

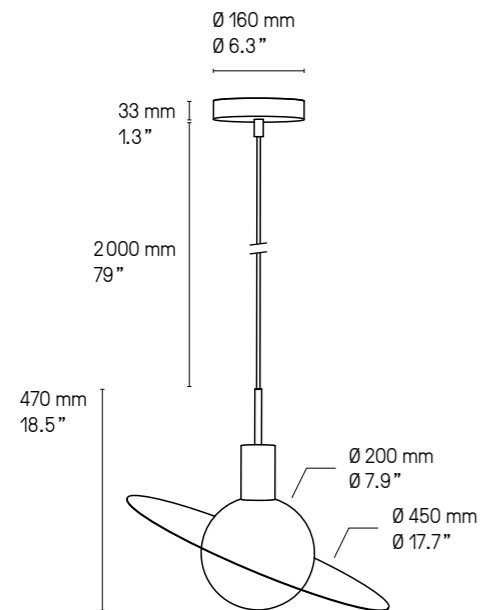

**Saturne XS (not dimmable for 110V)**

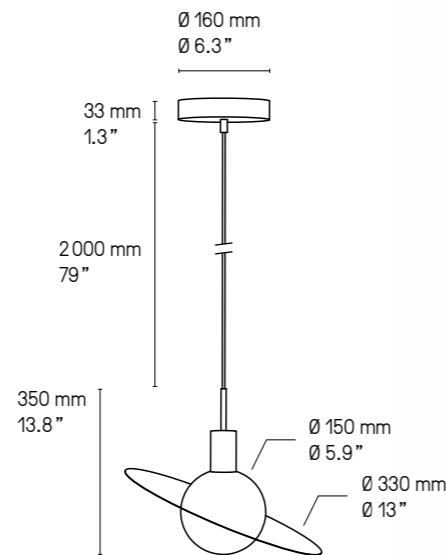

Saturne XL SB

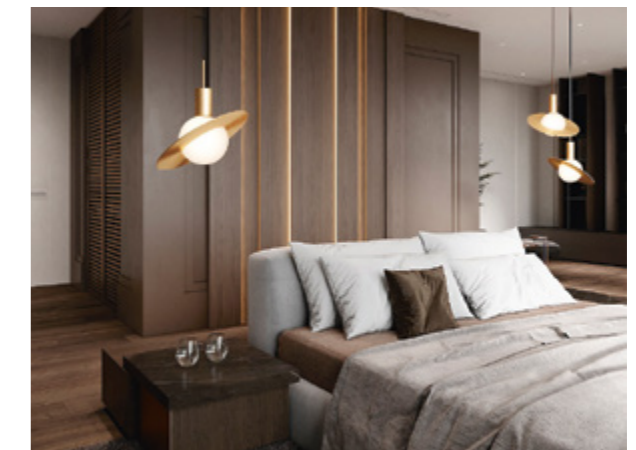

Saturne XL & XS SB

Il est possible de rassembler plusieurs suspensions sur un seul pavillon, circulaire ou rectangulaire. La version rectangulaire peut être adaptée à n'importe quelle longueur. La version circulaire a un diamètre maximum indiqué sur les croquis ci-dessus. Pour plus de renseignements, veuillez nous contacter.

It is possible to cluster several pendants from one single canopy, either rectangular or circular. The rectangular canopy can be custom-made into any size to suit your requirements. As for the circular canopy, available sizes are illustrated above. Please contact us for further information.





## SIGNAL

Apporter des lettres de noblesse au néon d'antan, voici l'esprit de la collection *Signal*. Véritable clin d'œil élégant, l'originalité de la source lumineuse désaxée se décline en appliques et suspensions.



Bringing something ancient back to fashion, this is what Pauline had in mind for the *Signal* collection. An elegant allusion, declined in wall lights and pendants, with their original asymmetric light source.



Signal V 540

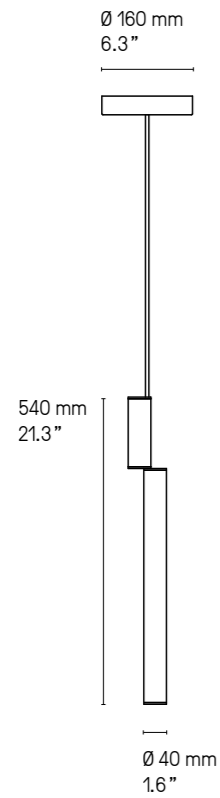

Signal V 440

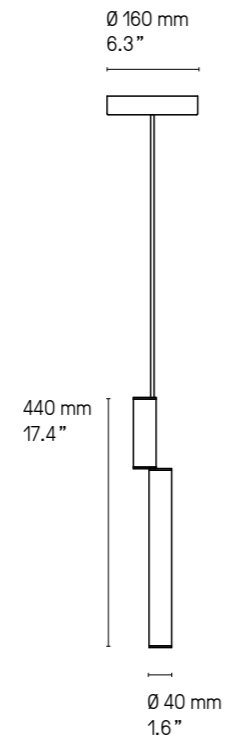

Signal V 340

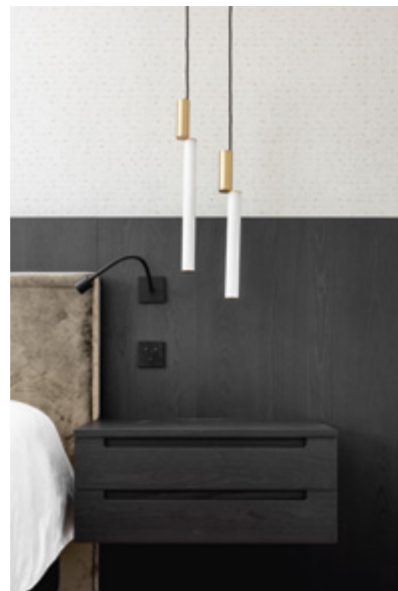
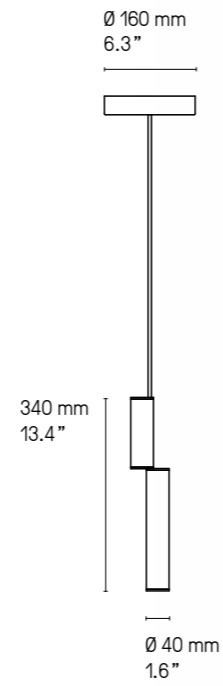

Signal V 540 + V 440 SB

Signal H 970

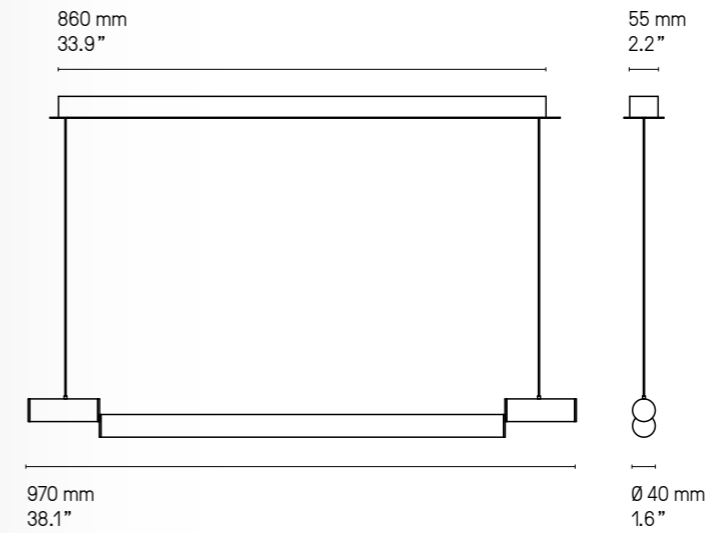

Signal H 770

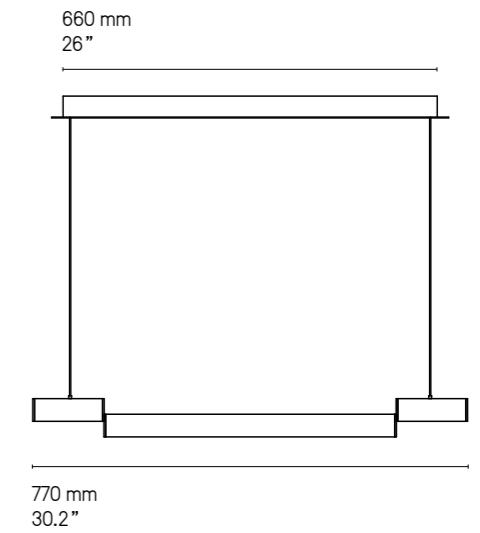

US Version  
fitted plate to cover  
outlet power box

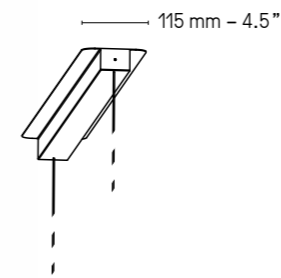

Signal H 770 SB



**Signal double 920**

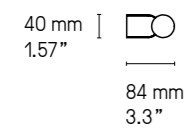
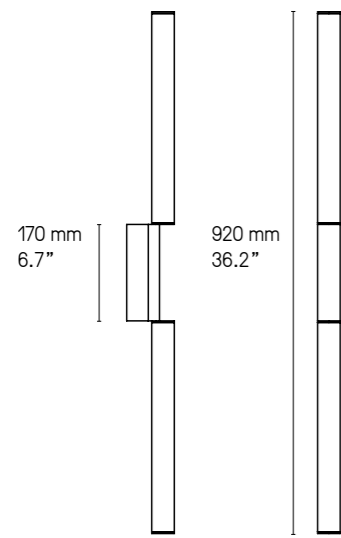

**Signal double 720**

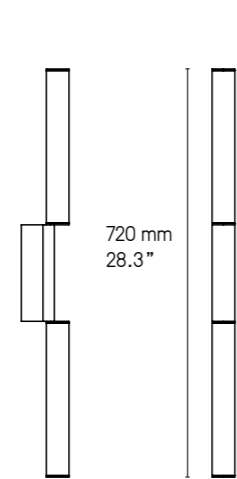

**Signal double 520**

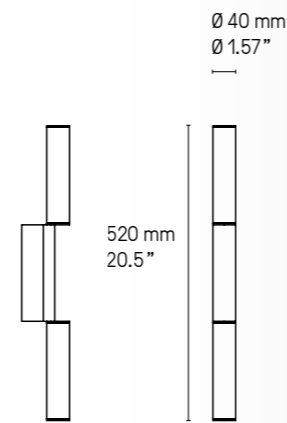

**Signal simple 545**

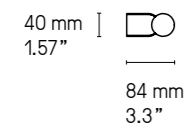
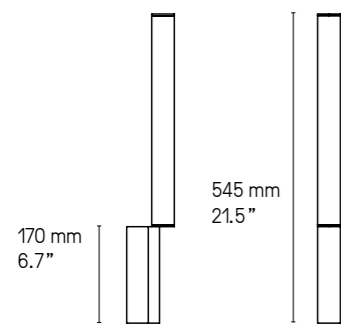

**Signal simple 445**

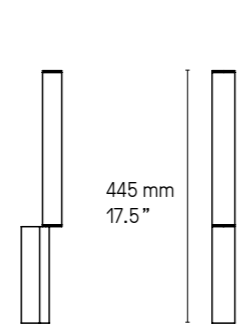

**Signal simple 345**

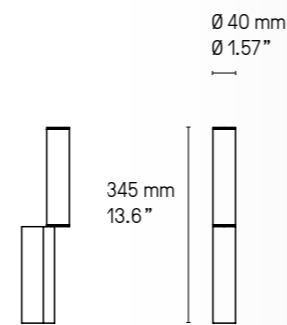

**UL Version  
fitted plate to cover outlet power box**

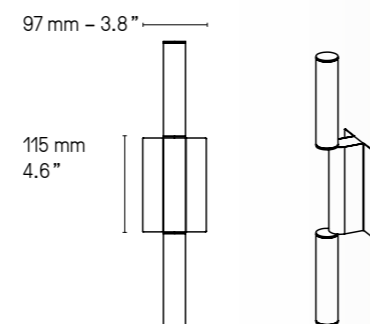

Signal peut être installée horizontalement ou verticalement.  
Signal can be placed both horizontally or vertically on the wall.



Signal Simple 445 PN



Signal Simple 445 PB



Signal Double 720 SB



Signal Pivot SB

Signal Duo

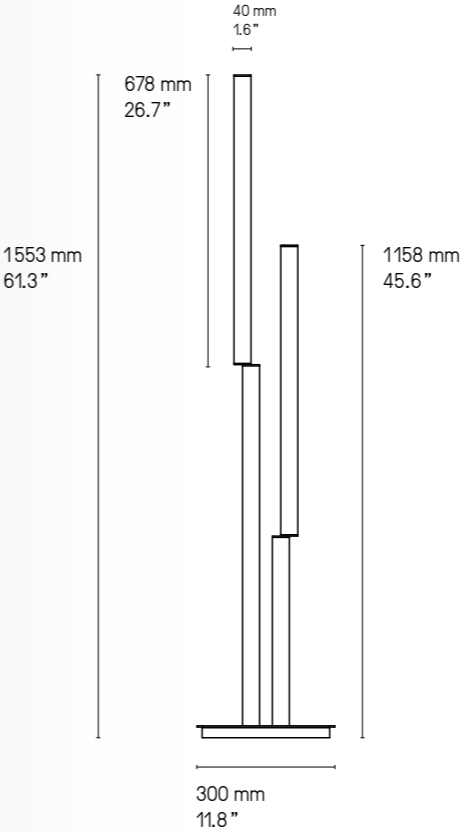

Signal Duo SB

Signal Pivot

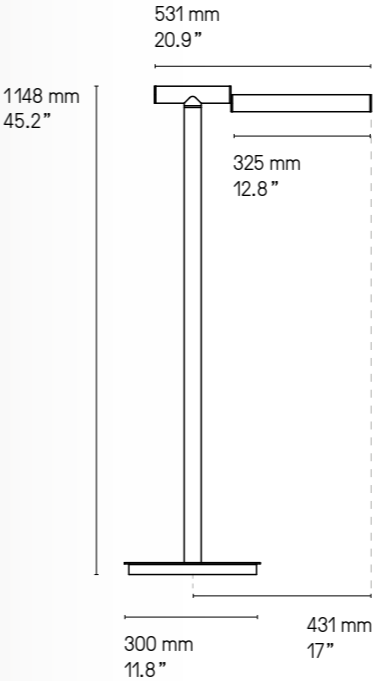

Signal Pivot SB



Signal Duo SB

**Signal Solo 176**

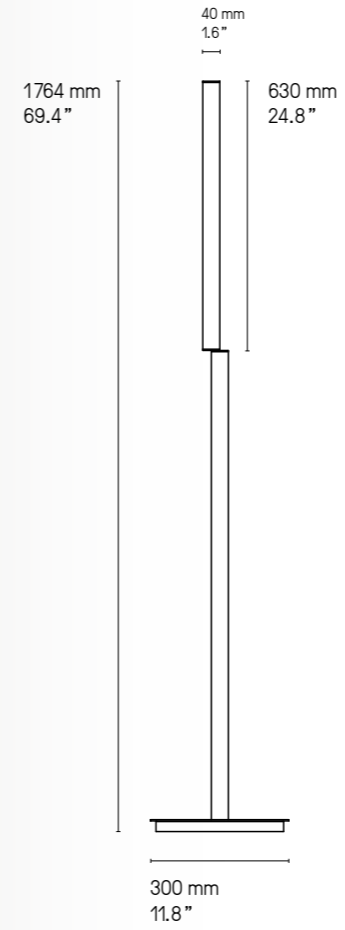

Signal Solo 176 SN

**Signal Solo 115**

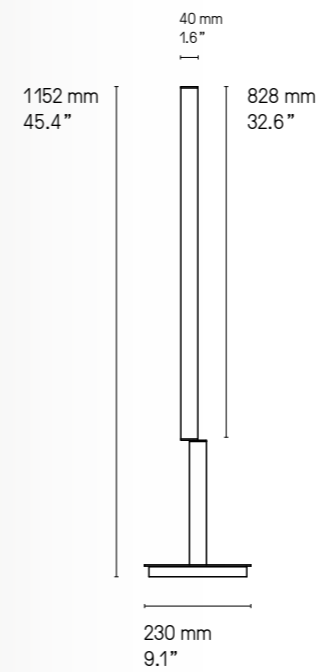

Signal Solo 115 SG



## SOLITAIRE

Ce lampadaire trépied, rehaussé d'un abat-jour à facettes, courtise le bicolore. Personnalisable à souhait, cette pièce unique s'approprie avec élégance vos choix de finitions.



This three-legged floor lamp, enhanced by a faceted lampshade, is even more flattering in a two-tone finish. This unique piece, which can be customized, elegantly blends together with your choice of finishes.



**Finitions**  
**Finishes** ①+②

Détails page 222

● Laiton satiné SB Satin brass	● Graphite satiné SG Satin graphite	● Nickel satiné SN Satin nickel	● Cuivre satiné SC Satin copper
● Laiton poli PB Polished brass	● Graphite poli PG Polished graphite	● Nickel poli PN Polished nickel	● Cuivre poli PC Polished copper

**Abat-jour**  
**Lampshade**

■ Chinette noire Black chinette	□ Chinette blanche White chinette
------------------------------------	--------------------------------------

**Matériaux**  
**Material**

Laiton massif Solid Brass	Abat-jour tissu Textile lampshade	Câble textile noir (longueur ≈ 1.5 m) Black textile cable (length ≈ 59")
------------------------------	--------------------------------------	---

**Source**  
**Lamping**

1 x E27 205 W max. Ampoule non fournie 1 x E27 205 W max. Bulb not included	Variateur à pied Foot operated dimmer	Variation* Dimming*
1 x E26 type A 150 W. Bulb not included	Foot operated switch	



**Designer**

Émilie Cathelineau

\* Les luminaires variables nécessitent l'utilisation d'ampoules compatibles avec la variation  
All dimmable light fixtures require the use of compatible bulbs

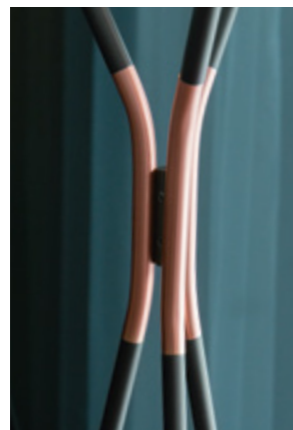

Solitaire XS SB/PB

Solitaire XL SG/SC

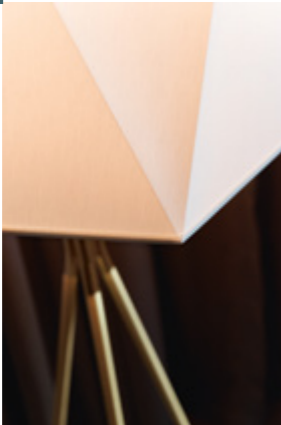

**Solitaire XL**

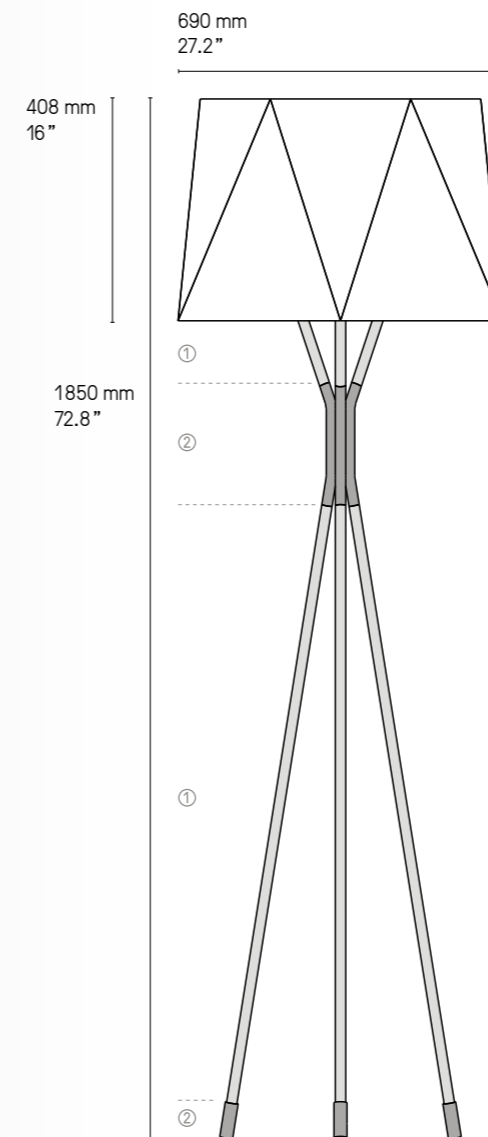
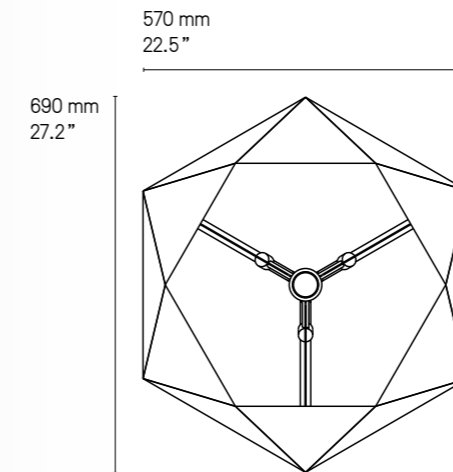

**Solitaire XS**

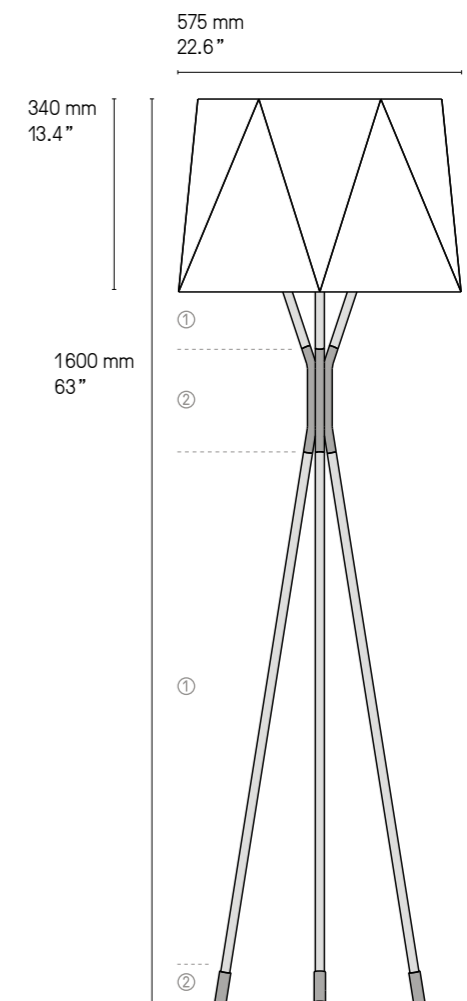
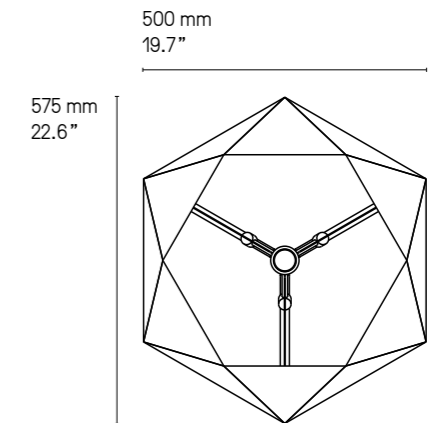

Version LED et DALI sur demande.  
LED and DALI version upon request.



## STORM

Lumière dirigée pour cette réinterprétation de la lampe tempête. La suspension et la lampe *Storm* affichent des lignes épurées, en toute intimité.



A reinterpretation of a storm made by light. The *Storm* pendant and lamp show off delicate and refined lines.

<b>Finitions</b> <b>Finishes</b>	● Laiton satiné	● Graphite satiné	● Nickel satiné	● Cuivre satiné
	SB Satin brass	SG Satin graphite	SN Satin nickel	SC Satin copper
<i>Détails page 222</i>				
	● Laiton poli	● Graphite poli	● Nickel poli	● Cuivre poli
	PB Polished brass	PG Polished graphite	PN Polished nickel	PC Polished copper

<b>Matériaux</b> <b>Material</b>	<b>Tous – All</b>	<b>Lampe de table – Table lamp</b> <i>Storm diffuser</i>	<b>Suspension – Pendant</b>
	Laiton massif Solid Brass	Diffuseur polycarbonate blanc White Polycarbonate diffuser	Câble métallique gainé <i>La longueur standard des câbles est de 2 mètres mais elle peut être diminuée à l'installation.</i> Sheathed metal cable. <i>The standard height of the cables is 2 meters (79") but can be adjusted to less during installation.</i>

<b>Source</b> <b>Lamping</b>	<b>Suspension – Pendant</b>		
	LED intégrée 630 lm 2700°K	Alimentation intégrée dans le pavillon	Variable (phase cut)
	Integrated LED 630 lm 2700°K	Int. power supply included in canopy	Dimmable (phase cut)
	<b>Applique diffuseur – Wall lamp diffuser</b>		
	LED intégrée 380 lm 2700°K	Alim. intégrée	
	Integrated LED 380 lm 2700°K	Internal power supply	
<b>Lampe de table diffuseur – Table lamp diffuser</b>			
LED intégrée 380 lm 2700°K	Alim. intégrée sur la prise		
Integrated LED 380 lm 2700°K	Plug-in power supply		
<b>Lampadaire diffuseur – Floor lamp diffuser</b>			
LED intégrée LED 1150 lm 2700°K	Alim. intégrée sur la prise		
Integrated LED 1150 lm 2700°K	Plug-in power supply		

**Designer** Émilie Cathelineau

**Lampe de table diffuseur – Table lamp diffuser**

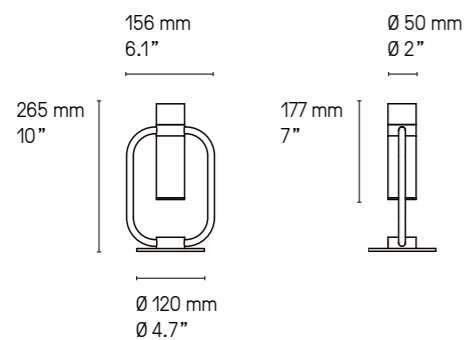

Lampe de table – Table lamp  
Storm diffuser SG

**Applique diffuseur – Wall light diffuser**

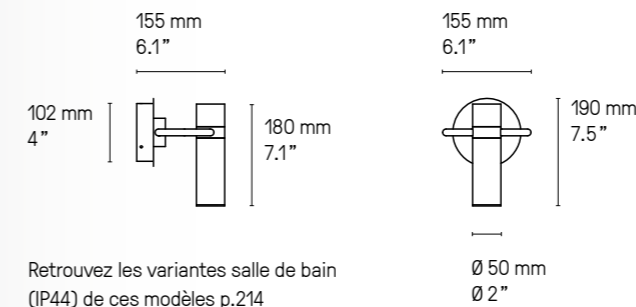

Retrouvez les variantes salle de bain (IP44) de ces modèles p.214  
You will find the bathroom variants (IP44) of these designs p.214

**US Version**  
fitted plate to cover outlet power box

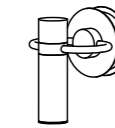

Applique – Wall light  
Storm diffuser SB

**Lampadaire diffuseur – Floor lamp diffuser**

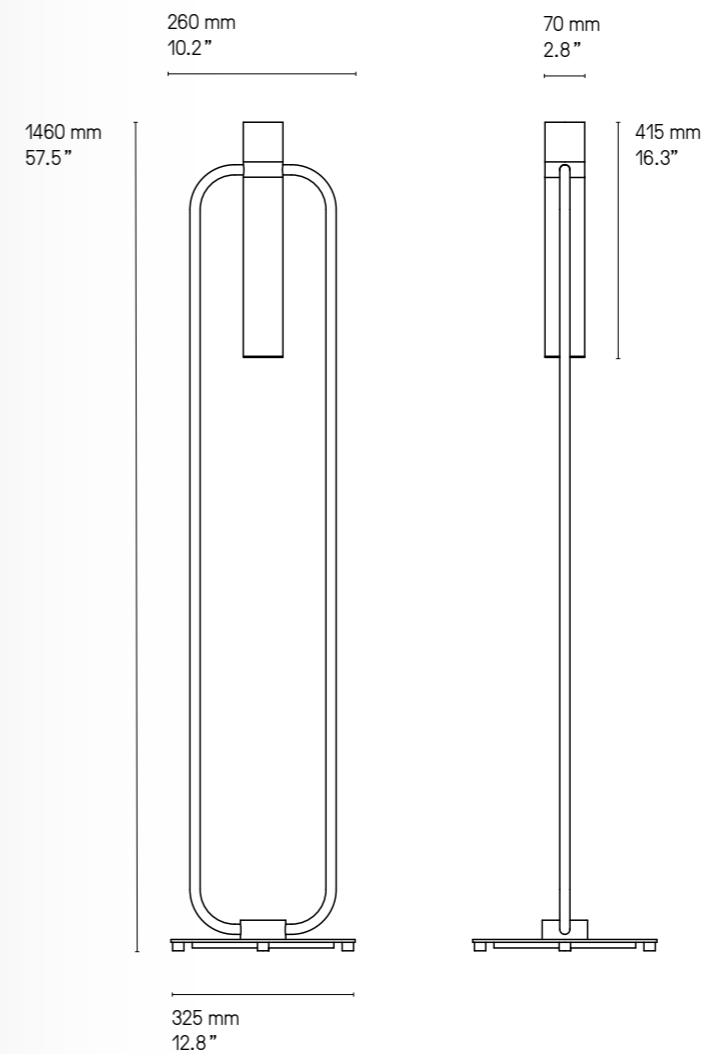

Lampadaire – Floor lamp  
Storm diffuser SB

Suspension – Pendant

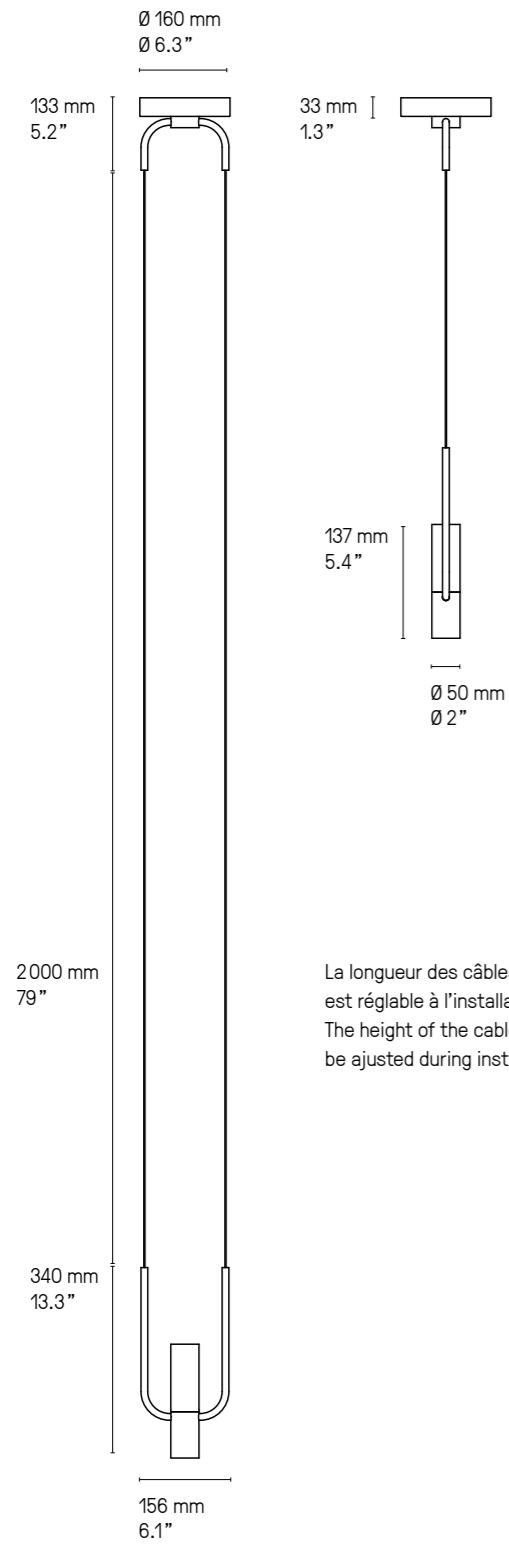

La longueur des câbles est réglable à l'installation.  
The height of the cables can be adjusted during installation.



Suspension – Pendant Storm SB

Suspension – Pendant Storm SG



Suspension – Pendant Storm SB



## STRATE

Collection de formes reliées par un trait lumineux, *Strate*, véritable sculpture, orne le mur aussi bien à la verticale qu'à l'horizontale. Par ses dimensions généreuses, elle habille l'espace et en devient une pièce maîtresse.



A collection of shapes linked by a luminous line, *Strate*, an authentic sculpture, adorns the wall both vertically and horizontally. With its generous dimensions, it covers the room and becomes a centerpiece.

**Finitions**  
**Finishes** ①+②

- Laiton satiné / **SB** Satin brass
- Graphite satiné / **SG** Satin graphite
- Nickel satiné / **SN** Satin nickel
- Cuivre satiné / **SC** Satin copper

Détails page 222

<b>Matériaux</b> <b>Material</b>	Laiton massif Solid Brass	Diffuseur en polycarbonate Polycarbonate diffuser
-------------------------------------	------------------------------	--

<b>Source</b> <b>Lamping</b>	LED intégrée Integrated LED	3000 lm* 3000 lm*	2700°K 2700°K	Alim. électronique 24 V intégrée Integrated 24 V power supply	Variable (phase cut) Dimmable (phase cut)
---------------------------------	--------------------------------	----------------------	------------------	--	--

**Designer** Émilie Cathelineau

\* Flux lumineux à l'avant et à l'arrière de l'applique  
Luminous flow at the front and at the back of the wall light



Strate Score SG/SB

Chaque modèle peut s'installer à la verticale ou à l'horizontale.  
Each model can be installed vertically or horizontally.

**Strate Score**

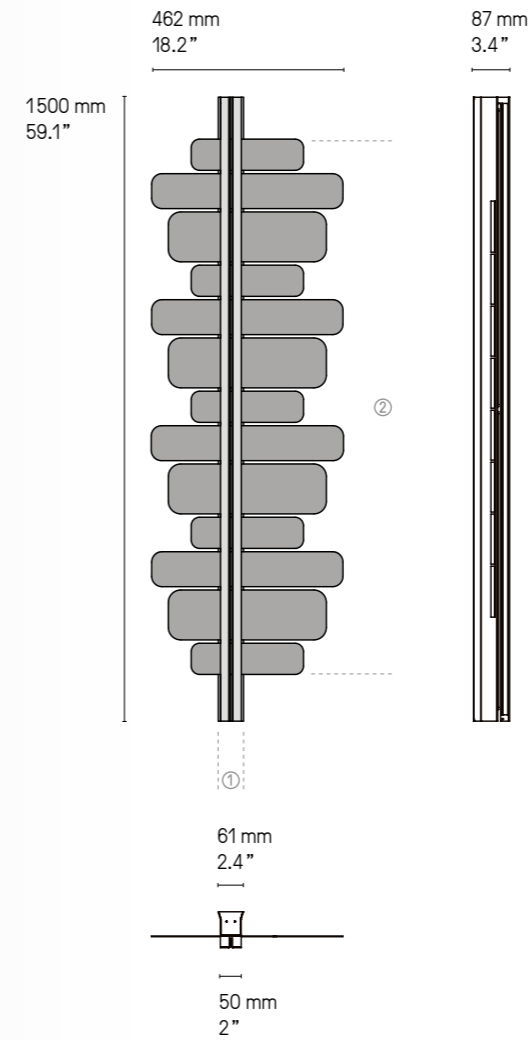

Strate Score SG/SB

**US Version**  
**fitted plate to cover outlet power box**

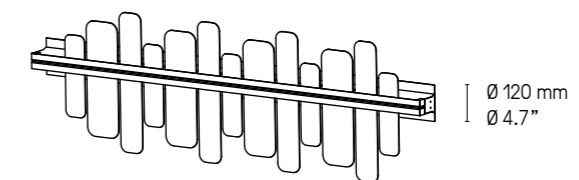

**Strate Stone**

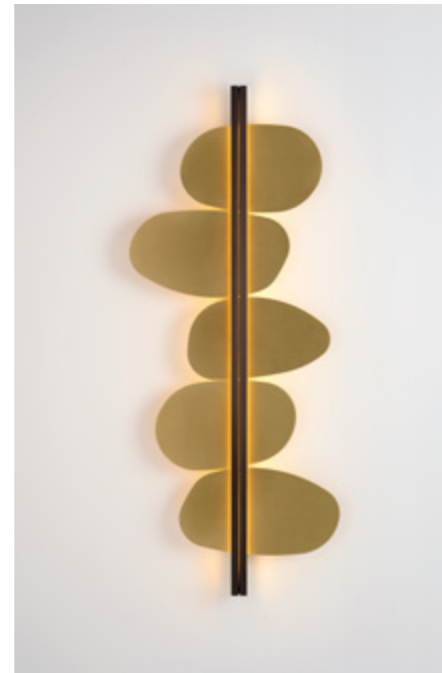
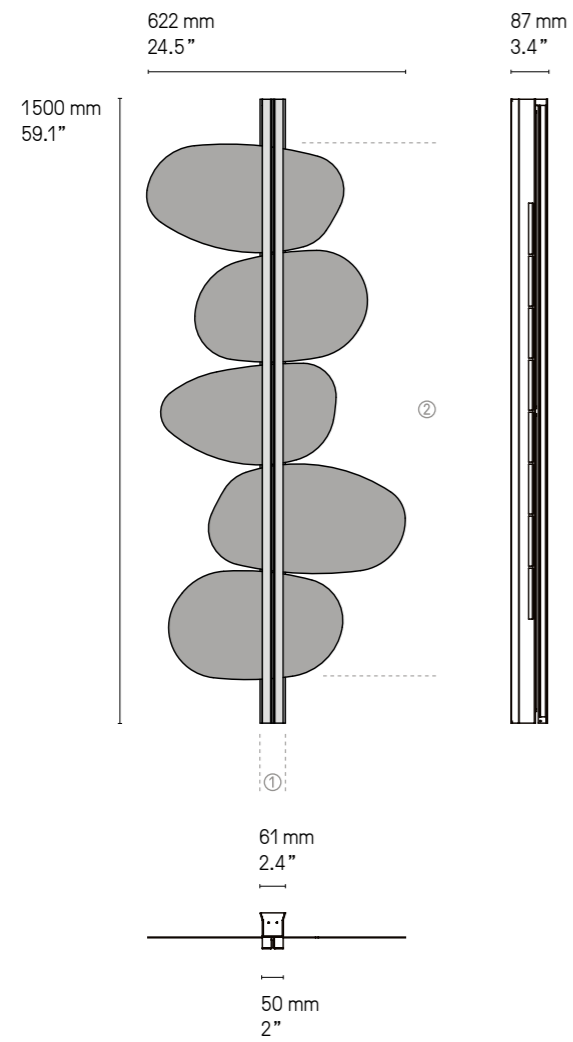

Strate Stone SG/SB



Strate Stone SB/SB

**Strate Spi**

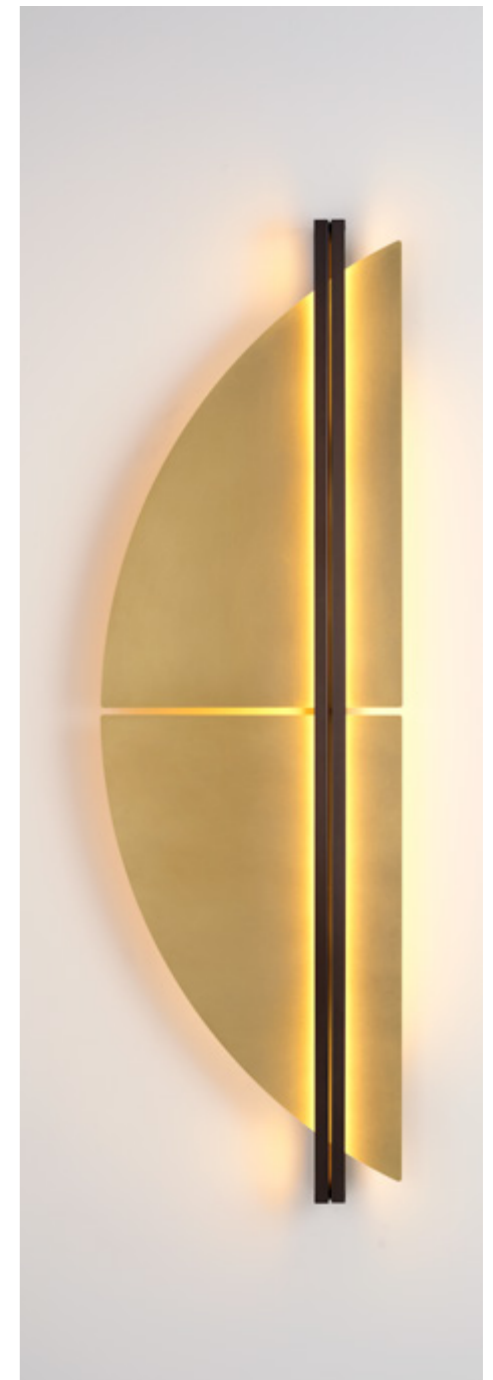
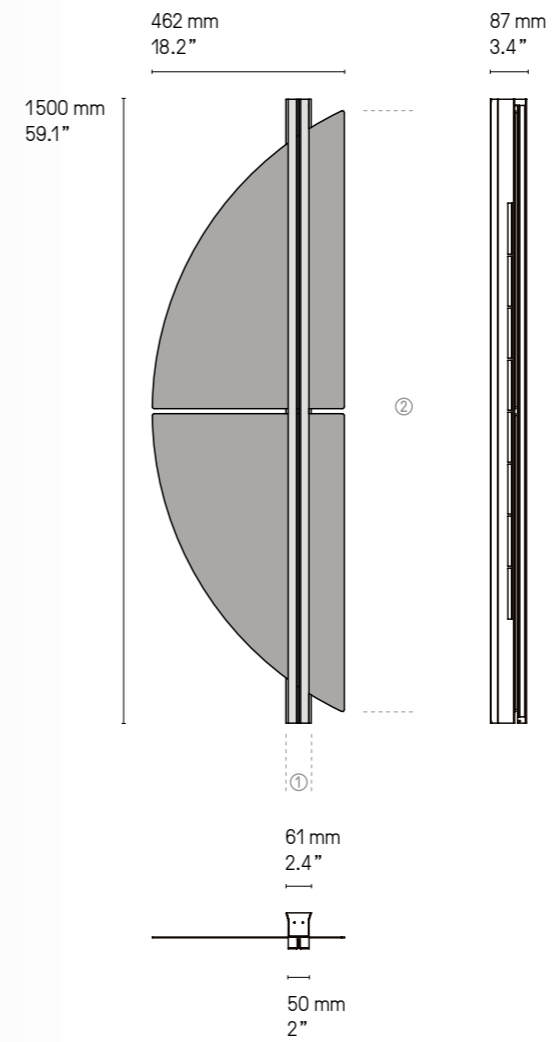

Strate Spi SG/SB

**Strate Moon**

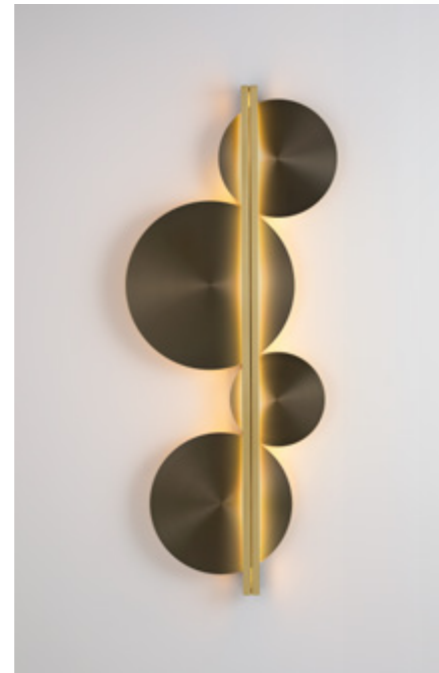
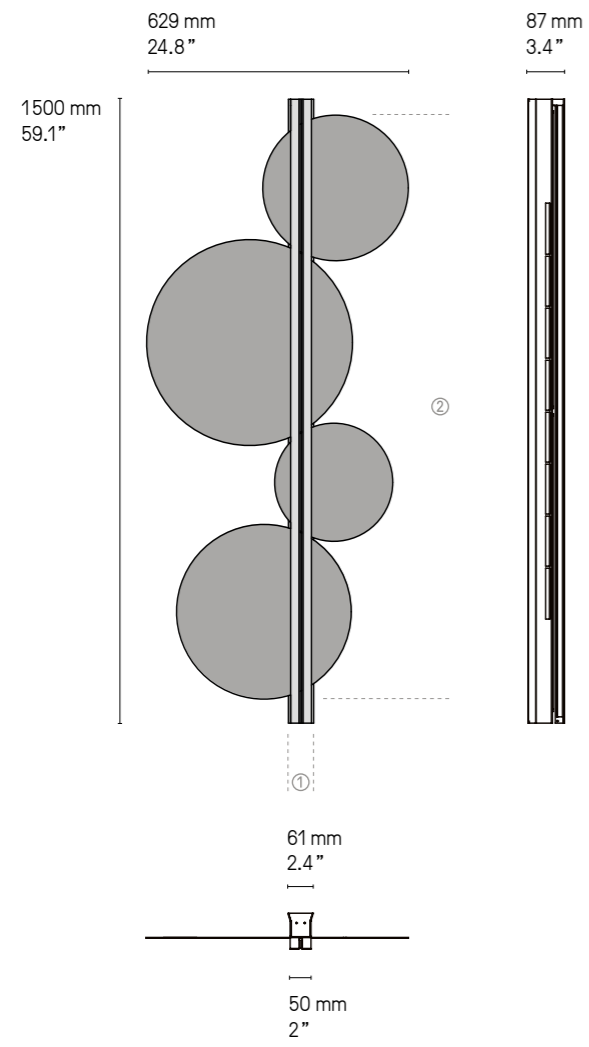

Strate Moon SB/SG

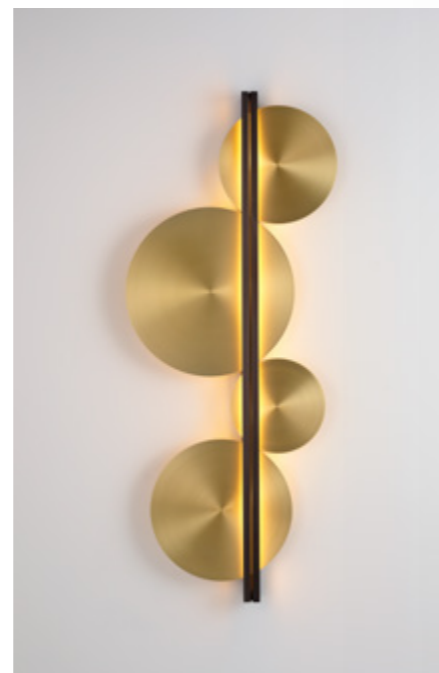

Strate Moon SG/SB



Strate Moon SG/SB





## TÉTRA

Seul ou en composition, le module triangulaire *Tétra* dessine par la lumière vos inspirations. Un objet sobre se multipliant à l'infini.



By itself or as an arrangement, the triangular module *Tétra* can shape your own creation with light. A simple object that can be multiplied endlessly.

**Finitions**  
**Finishes**

Détails page 222

● Laiton satiné SB Satin brass	● Graphite satiné SG Satin graphite	● Nickel satiné SN Satin nickel	● Cuivre satiné SC Satin copper
● Laiton poli PB Polished brass	● Graphite poli PG Polished graphite	● Nickel poli PN Polished nickel	● Cuivre poli PC Polished copper

**Matériaux**  
**Material**

Laiton massif Solid Brass	Diffuseur en polycarbonate Polycarbonate diffuseur
------------------------------	---

**Description**  
**Features**

Lorsqu'ils sont positionnés côte à côte, les luminaires *Tétra* peuvent être interconnectés grâce à un câble circulant entre le mur et l'arrière du luminaire. Ce montage ne nécessite qu'une seule sortie électrique. Veuillez noter que le système d'interconnexion n'est pas certifié UL.

Positioned side by side, *Tétra* lights can be interconnected with a cable that runs between the wall and the back of the lights. This arrangement requires only one electrical outlet. Please be aware that this interconnected system is not up to code in the US and is not UL certified.

**Source**  
**Lamping**

LED intégrée 900 lm 2700°K	Alim. électronique intégrée	Variation (phase cut)	
Integrated LED 900 lm 2700°K	Integrated power supply	Dimmable (phase cut). USA, please, contact us	

**Designer**

Émilie Cathelineau



Tétra SB

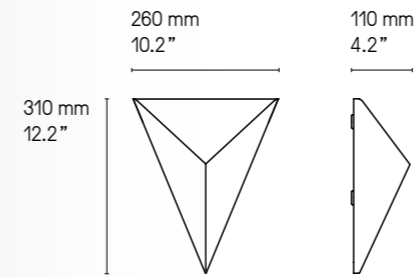

**Exemples de compositions**  
**Examples of arrangements**

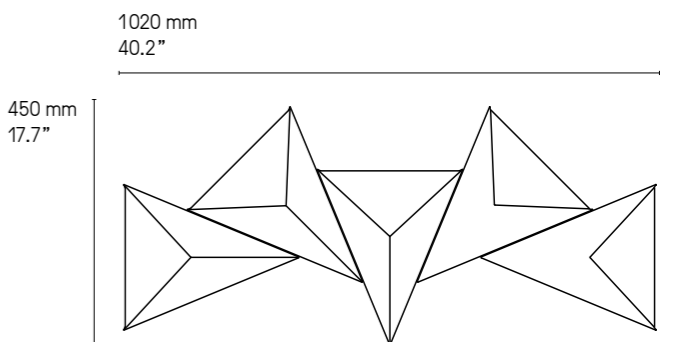
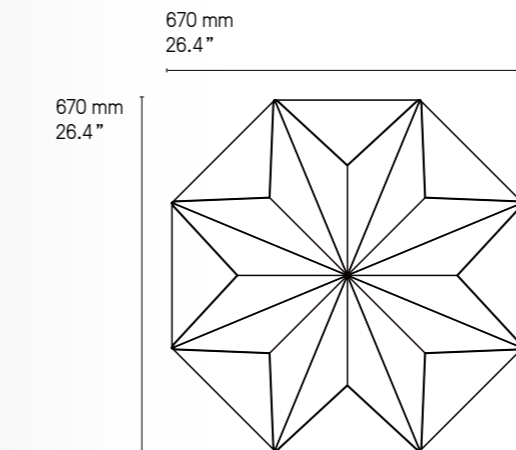
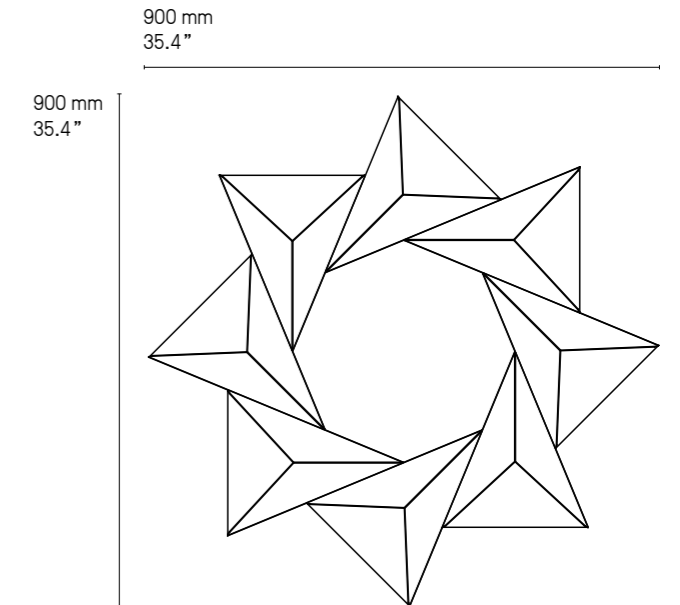
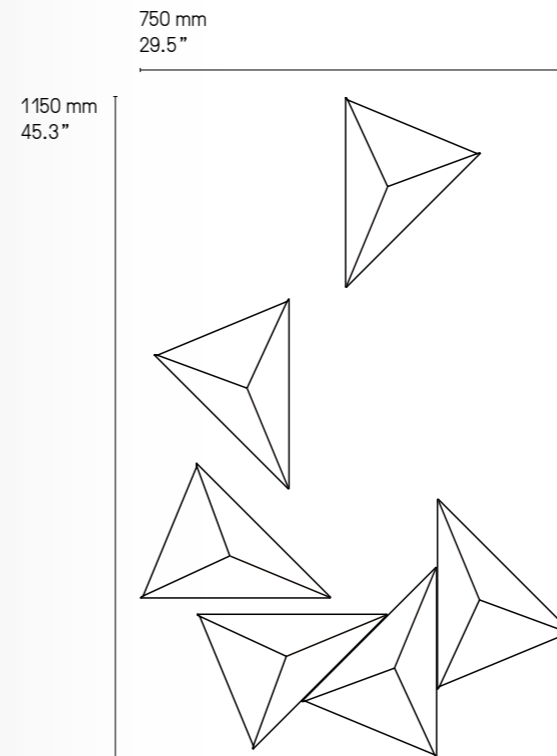



Tétra SB



Tétra SB



## UPPER

Lampadaire unique aux dimensions généreuses, *Upper* investit l'espace comme un objet à la fois utile et précieux. Inspiré des gratte-ciel de Manhattan, ses lignes invitent le regard à monter vers le ciel.



A unique floor lamp with large dimensions, *Upper* uses space as a valuable and useful object. Tall with straight brass tubes, this light is inspired by Manhattan's skyscrapers.

**Finitions  
Finishes**

Détails page 222

● Laiton satiné SB Satin brass	● Graphite satiné SG Satin graphite	● Nickel satiné SN Satin nickel	● Cuivre satiné SC Satin copper
● Laiton poli PB Polished brass	● Graphite poli PG Polished graphite	● Nickel poli PN Polished nickel	● Cuivre poli PC Polished copper

**Abat-jour  
Lampshade**

□ Drop Paper® 100	■ Drop Paper® 101	■ Drop Paper® 103
-------------------	-------------------	-------------------

**Matériaux  
Material**

Laiton massif Solid Brass	Abat-jour Drop Paper® M1 Lampshade Drop Paper® M1	Câble textile noir (longueur ≈ 2 m) Black textile cable (length ≈ 79")
------------------------------	--	---

**Source  
Lamping**

3 x E27 70 W max. Ampoule non fournie 3 x E27 70 W max. Bulb not included	Variateur à pied Foot operated dimmer	Variation* Dimming*
3 x E26 type A 150 W. Bulb not included	Foot operated switch	

**Designer**

Hervé Langlais

\* Les luminaires variables nécessitent l'utilisation d'ampoules compatibles avec la variation  
All dimmable light fixtures require the use of compatible bulbs

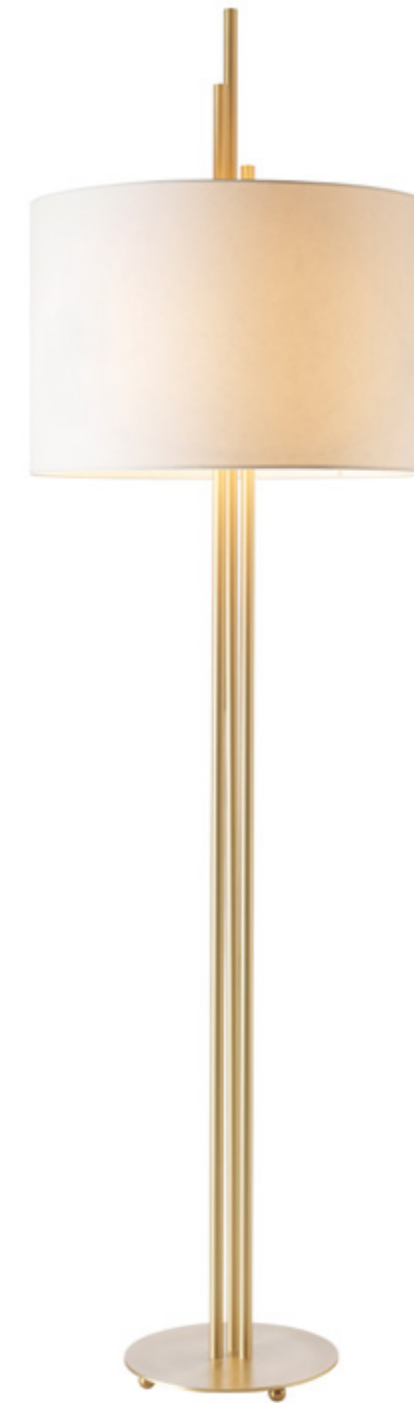
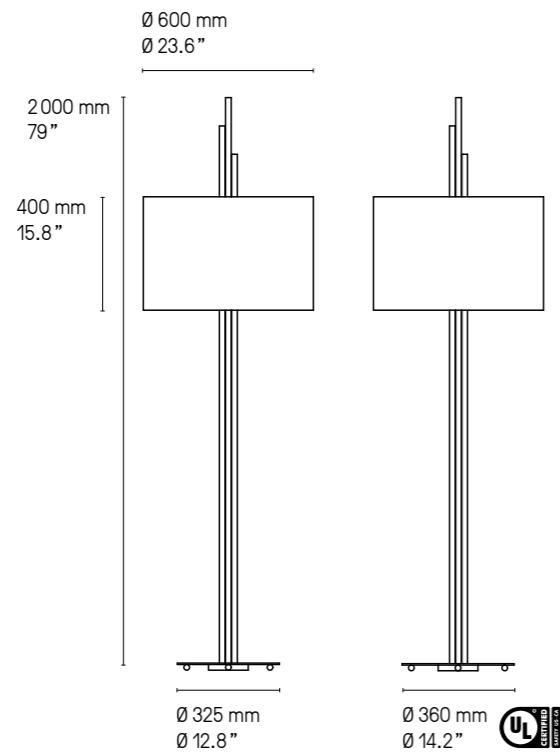

Upper SB

Version LED et DALI sur demande.  
LED and DALI version upon request.



## WONDER

Inspirée des lampes de poche de notre enfance, *Wonder* se décline en appliques et en lampes dans un format XL. Un brin de nostalgie dans cette collection aux nombreuses variantes grâce à une gamme de couleurs originales, mariées à nos finitions métalliques.



Inspired by our childhood's flashlights, *Wonder* offers a variety of wall lights and XL lamps. An ounce of nostalgia in this wide-ranging collection with several original colors available, combined with metal finishing.

**Finitions Finishes** ①

Détails page 222

● Laiton satiné SB Satin brass	● Graphite satiné SG Satin graphite	● Nickel satiné SN Satin nickel	● Cuivre satiné SC Satin copper
● Laiton poli PB Polished brass	● Graphite poli PG Polished graphite	● Nickel poli PN Polished nickel	● Cuivre poli PC Polished copper

**Finitions Finishes** ②

Détails page 222

● Bleu foncé DB Dark Blue	● Bleu clair LB Light Blue	● Goyave GU Guava	● Bordeaux DR Dark Red
● Mangue MA Mango	● Vert vintage VG Vintage Green		
● Laiton satiné SB Satin brass	● Graphite satiné SG Satin graphite	● Nickel satiné SN Satin nickel	● Cuivre satiné SC Satin copper

**Matériaux Material**

<b>Tous – All</b> Laiton massif et acier peint Solid Brass and painted steel	Diffuseur PMMA blanc texturé Textured white PMMA diffuser	<b>Lampe de Table – Table Lamp</b> Câble textile noir Black textile cable
--	--	---

**Source Lamping**

<b>Lampe de table – Table lamp</b> LED intégrée 1100 lm 2700°K Integrated LED 1100 lm 2700°K	Alim. intégrée 110-220V Power supply 110-220V	Variable Dimmable
<b>Appliques – Wall lights</b>		
<b>Applique – Wall light XS</b> LED intégrée 430 lm 2700°K Integrated LED 430 lm 2700°K	230V direct / 120V direct 230V direct / 120V direct	Variable (phase cut) Dimmable (phase cut)
<b>Applique – Wall light XL</b> LED intégrée 430 lm 2700°K Integrated LED 430 lm 2700°K	230V direct / 120V direct 230V direct / 120V direct	Variable (phase cut) Dimmable (phase cut)

**Designer**

Émilie Cathelineau



Bouton de variation au dos de la lampe  
Dimming button at the back of the lamp

**Lampe de table – Table lamp**

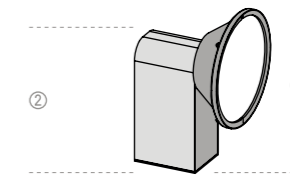
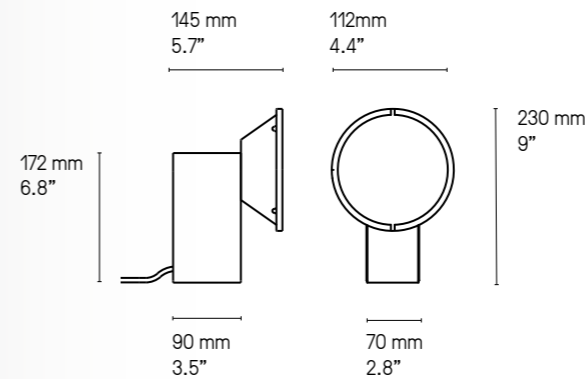

**Lampes de table – Table lamps**

- |                |                |
|----------------|----------------|
| A Wonder PB/SG | E Wonder SG/SB |
| B Wonder PG/MA | F Wonder SN/LB |
| C Wonder PN/DR | G Wonder SG/VG |
| D Wonder SB/GU | H Wonder SB/DB |

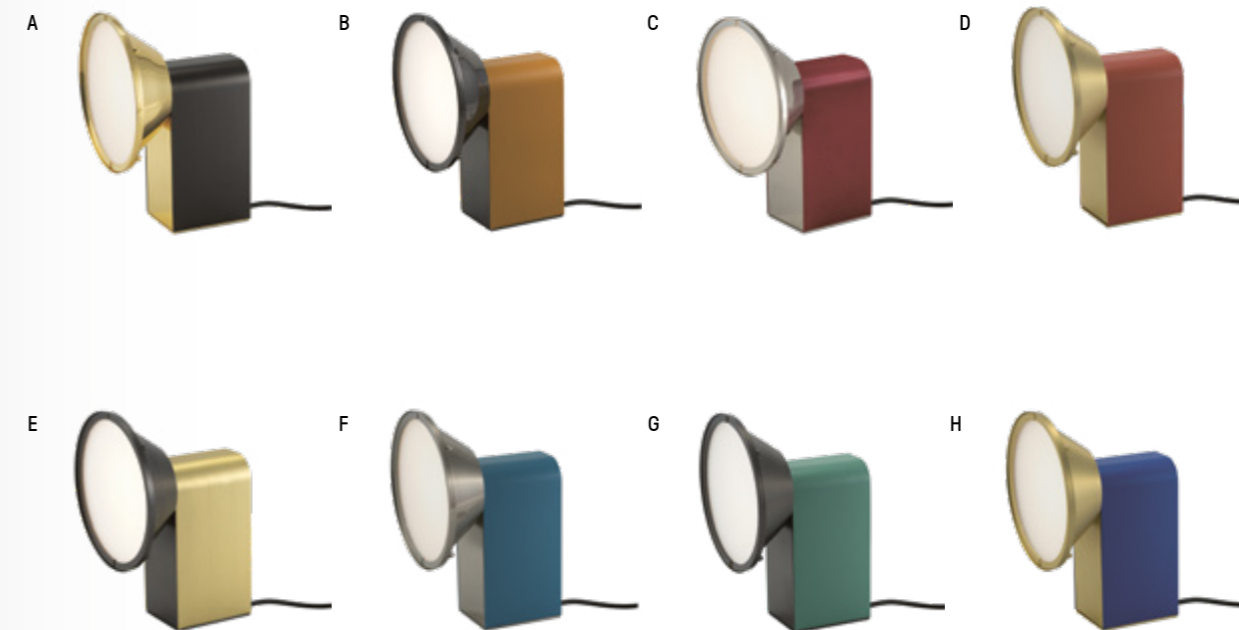

Applique XS V1 – Wall light XS V1

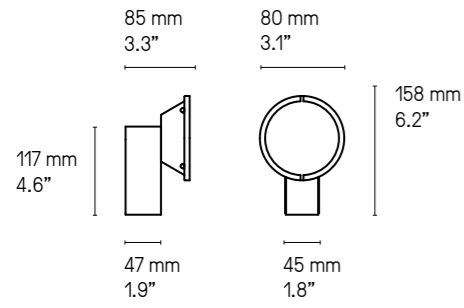

Applique XL V1 – Wall light XL V1

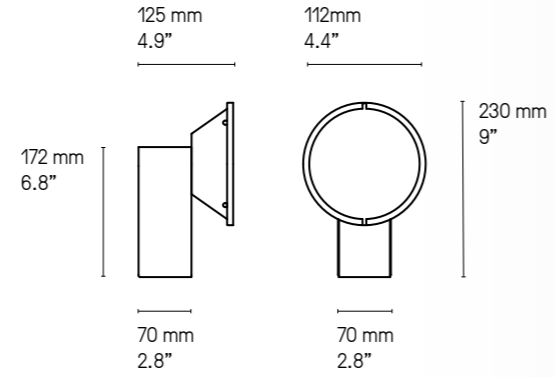

XL V1 SB/SG



XL V1 SN/LB



XL V1 SG/SB



XL V1 SG/MA

Les appliques *Wonder* ne sont pas réglables. V1 et V2 sont des modèles différents.  
*Wonder* wall lights are not mobile. V1 and V2 are different fixed models.

Applique XS V2 – Wall light XS V2

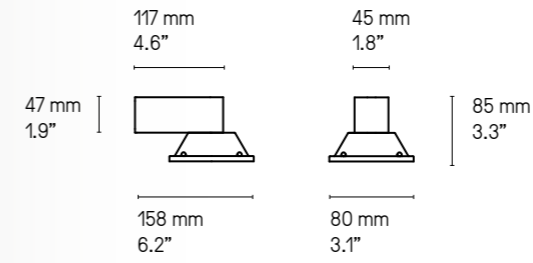

Applique XL V2 – Wall light XL V2

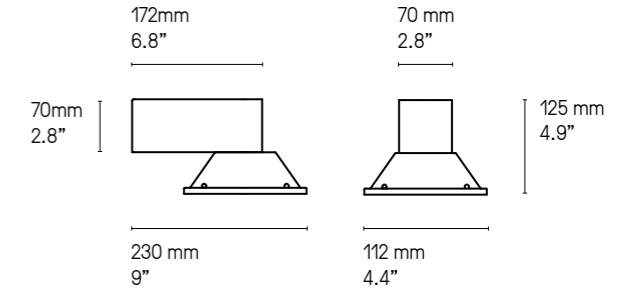

XL V2 SB/DR



XL V2 SB/GU



XL V2 SB/VG



XS V2 SB/DB

Les appliques *Wonder* ne sont pas réglables. V1 et V2 sont des modèles différents.  
*Wonder* wall lights are not mobile. V1 and V2 are different fixed models.





CVL

## APPLIQUES SALLE DE BAIN BATHROOM WALL LIGHTS

Élégance des formes, aux accents minimalistes et aux finitions soignées. Retrouvez l'esprit CVL dans une collection d'appliques esthétiques et fonctionnelles, spécifiquement conçues pour la salle de bain.



Elegant shapes, minimalist accents and immaculate finishes. Find the CVL spirit in a collection of aesthetic and functional wall lights, specifically designed for bathrooms.



# IP BACKSTAGE



## Finitions Finishes

Détails page 222

● Laiton satiné <b>SB</b> Satin brass	● Graphite satiné <b>SG</b> Satin graphite	● Nickel satiné <b>SN</b> Satin nickel	● Cuivre satiné <b>SC</b> Satin copper
● Laiton poli <b>PB</b> Polished brass	● Graphite poli <b>PG</b> Polished graphite	● Nickel poli <b>PN</b> Polished nickel	● Cuivre poli <b>PC</b> Polished copper

## Matériaux Material

Laiton massif Solid Brass	Verre triplex opale soufflé bouche Opal triplex mouth-blown glass
------------------------------	--

## Source Lamping

<b>IP Backstage 4</b>				
LED intégrée	480 lm	3 000° K	Alimentation 24 V intégrée	Non variable en standard
Integrated LED	480 lm	3 000° K	Int. power supply 24 V included	Standard version not dim.
<b>IP Backstage 6</b>				
LED intégrée	720 lm	3 000° K	Alimentation 24 V intégrée	Non variable en standard
Integrated LED	720 lm	3 000° K	Int. power supply 24 V included	Standard version not dim.
<b>IP Backstage 8</b>				
LED intégrée	960 lm	3 000° K	Alimentation 24 V intégrée	Non variable en standard
Integrated LED	960 lm	3 000° K	Int. power supply 24 V included	Standard version not dim.
<b>IP Backstage Corner 4</b>				
LED intégrée	480 lm	3 000° K	Alimentation 24 V intégrée	Non variable en standard
Integrated LED	480 lm	3 000° K	Int. power supply 24 V included	Standard version not dim.
<b>IP Backstage Corner 6</b>				
LED intégrée	720 lm	3 000° K	Alimentation 24 V intégrée	Non variable en standard
Integrated LED	720 lm	3 000° K	Int. power supply 24 V included	Standard version not dim.
<b>IP Backstage Corner 8</b>				
LED intégrée	960 lm	3 000° K	Alimentation 24 V intégrée	Non variable en standard
Integrated LED	960 lm	3 000° K	Int. power supply 24 V included	Standard version not dim.

## Norme Standard

IP44	Classe II
IP44	Class II

## Designer

Émilie Cathelineau

**IP Backstage Linear L8**

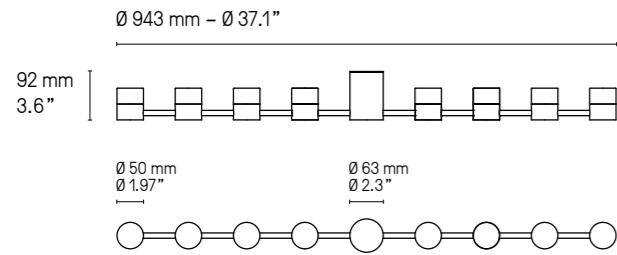

**IP Backstage Corner C8**

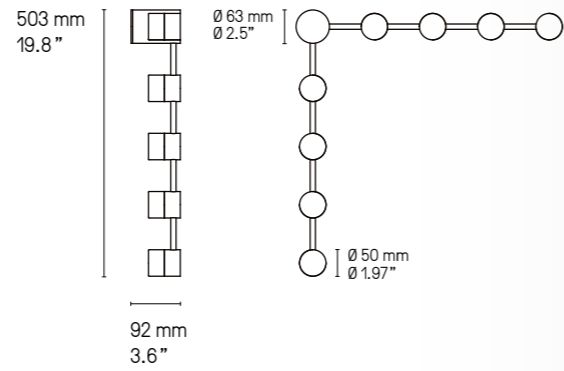

**IP Backstage Linear L6**

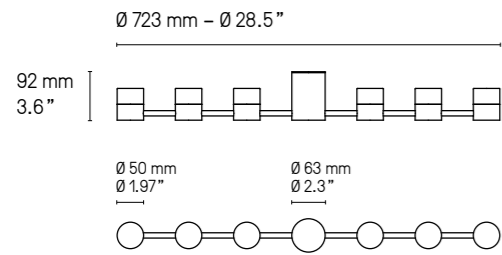

**IP Backstage Corner C6**

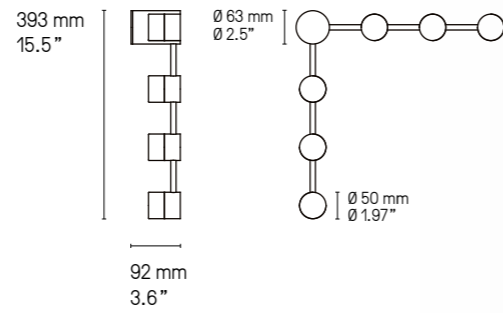

**IP Backstage Linear L4**

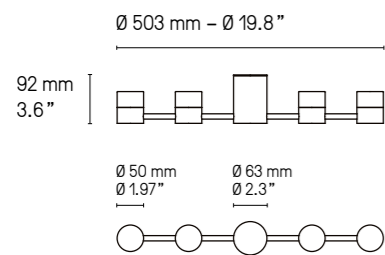

**IP Backstage Corner C4**

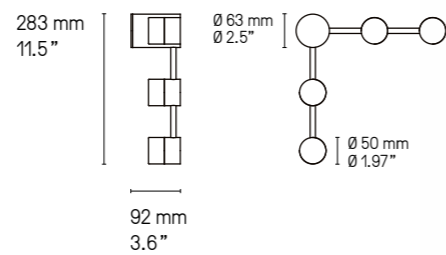

**US Version  
fitted plate to cover outlet power box**

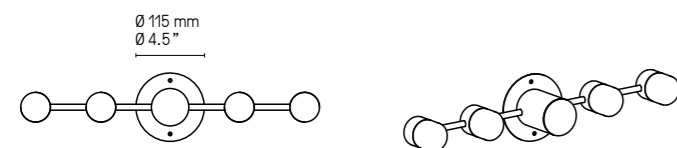



IP Backstage Corner C8 SG



IP Backstage Linear L6 PN



IP Backstage Linear L4 SB



IP Backstage Linear L6 SG



IP Backstage Corner C8 PB



# IP CALÉ(E)



## Finitions Finishes ① + ②

Détails page 222

● Laiton satiné <b>SB</b> Satin brass	● Graphite satiné <b>SG</b> Satin graphite	● Nickel satiné <b>SN</b> Satin nickel	● Cuivre satiné <b>SC</b> Satin copper
● Laiton poli <b>PB</b> Polished brass	● Graphite poli <b>PG</b> Polished graphite	● Nickel poli <b>PN</b> Polished nickel	● Cuivre poli <b>PC</b> Polished copper

## Matériaux Material

Laiton massif Solid Brass	Diffuseur polycarbonate satiné Satin Polycarbonate diff user
------------------------------	---

## Source Lamping

LED intégrée Integrated LED	830 lm	3000° K	Alimentation 24 V intégrée Int. power supply 24 V included	Non variable en standard Standard version not Dimmable
--------------------------------	--------	---------	---	---

## Norme Standard

IP44	Classe II
IP44	Class II

## Designer

POOL

### VH

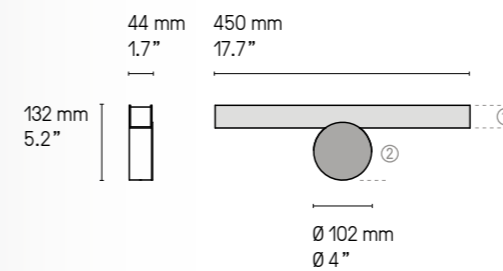

### VV

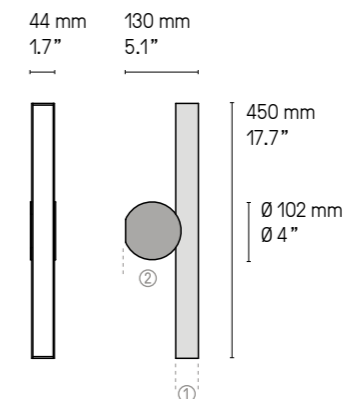

### VF

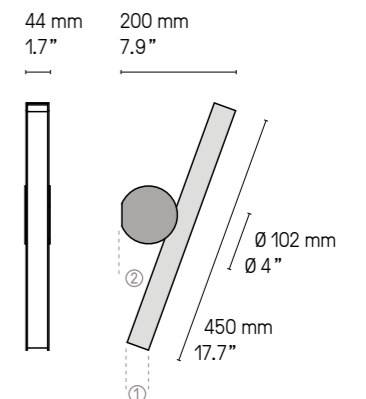

Les appliques Calé(e)s ne sont pas réglables. Ce sont 3 modèles différents.  
Calé(e) wall lights are not mobile. These are 3 different fixed models.



# IP CORNET



## Finitions Finishes

Détails page 222

● Laiton satiné <b>SB</b> Satin brass	● Graphite satiné <b>SG</b> Satin graphite	● Nickel satiné <b>SN</b> Satin nickel	● Cuivre satiné <b>SC</b> Satin copper
● Laiton poli <b>PB</b> Polished brass	● Graphite poli <b>PG</b> Polished graphite	● Nickel poli <b>PN</b> Polished nickel	● Cuivre poli <b>PC</b> Polished copper

## Matériaux Material

Laiton massif Solid Brass	Verre triplex opale soufflé bouche Opal triplex mouth-blown glass
------------------------------	--

## Source Lamping

G9 LED 5W max. non fournie G9 LED 5W max. not included	Variable Dimmable
---	----------------------

## Norme Standard

IP24	Classe II
IP24	Class II

## Designer

POOL

\* Les luminaires variables nécessitent l'utilisation d'ampoules compatibles avec la variation  
All dimmable light fixtures require the use of compatible bulbs

## IP Cornet Appliques – Wall mounted lights

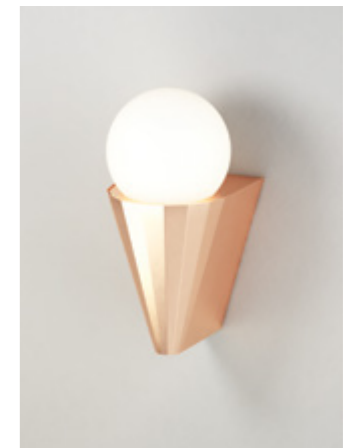
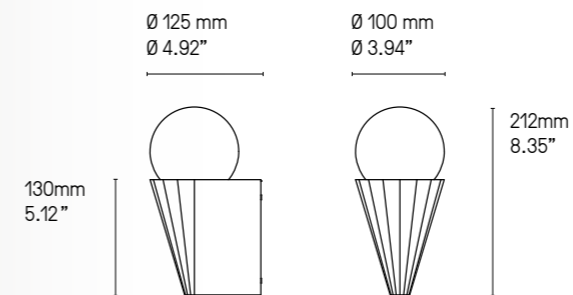

Appliques – Wall mounted lights  
Cornet SC



IP Cornet SB



IP Cornet SG



# IP GAMMA



## Finitions Finishes

Détails page 222

● Laiton satiné <b>SB</b> Satin brass	● Graphite satiné <b>SG</b> Satin graphite	● Nickel satiné <b>SN</b> Satin nickel	● Cuivre satiné <b>SC</b> Satin copper
● Laiton poli <b>PB</b> Polished brass	● Graphite poli <b>PG</b> Polished graphite	● Nickel poli <b>PN</b> Polished nickel	● Cuivre poli <b>PC</b> Polished copper

## Matériaux Material

Laiton massif Solid Brass	Diffuseur polycarbonate blanc White Polycarbonate diffuser
------------------------------	---

## Source Lamping

LED 500 lm 3000°K	Alimentation 24V intégrée Int. power supply 24V included	IP44 Non variable en standard IP44 Standard version not dimmable
-------------------	---	---

## Norme Standard

IP44	Classe II
IP44	Class II

## Designer

Sylvain Willenz

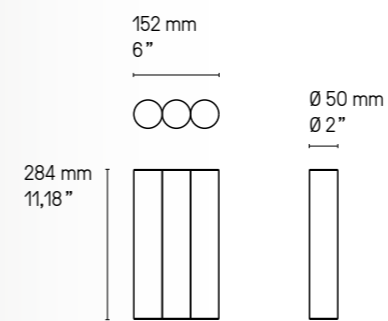

IP Gamma SB    IP Gamma SG    IP Gamma SN    IP Gamma SC





# IP LINK



## Finitions Finishes

Détails page 222

● Laiton satiné <b>SB</b> Satin brass	● Graphite satiné <b>SG</b> Satin graphite	● Nickel satiné <b>SN</b> Satin nickel	● Cuivre satiné <b>SC</b> Satin copper
● Laiton poli <b>PB</b> Polished brass	● Graphite poli <b>PG</b> Polished graphite	● Nickel poli <b>PN</b> Polished nickel	● Cuivre poli <b>PC</b> Polished copper

## Matériaux Material

Laiton massif Solid Brass	Diffuseur polycarbonate satiné Satin Polycarbonate diff user	Ruban Led sans points visibles Led strip without visible dots
------------------------------	---	--

## Source Lamping

<b>IP Link 410 (410 mm - 16.1")</b>			
LED intégrée	150 lm	3 000° K	Alimentation 24 V intégrée
Integrated LED	150 lm	3 000° K	Int. power supply 24 V included
<b>IP Link 580 (580 mm - 22.8")</b>			
LED intégrée	300 lm	3 000° K	Alimentation 24 V intégrée
Integrated LED	300 lm	3 000° K	Int. power supply 24 V included
<b>IP Link double 610 (610 mm - 24.1")</b>			
LED intégrée	300 lm	3 000° K	Alimentation 24 V intégrée
Integrated LED	300 lm	3 000° K	Int. power supply 24 V included
<b>IP Link double 960 (960 mm - 37.8")</b>			
LED intégrée	600 lm	3 000° K	Alimentation 24 V intégrée
Integrated LED	600 lm	3 000° K	Int. power supply 24 V included
<b>IP Link double 1300 (1300 mm - 51.2")</b>			
LED intégrée	800 lm	3 000° K	Alimentation 24 V intégrée
Integrated LED	800 lm	3 000° K	Int. power supply 24 V included

## Norme Standard

IP44	Classe II
IP44	Class II

## Designer

Émilie Cathelineau

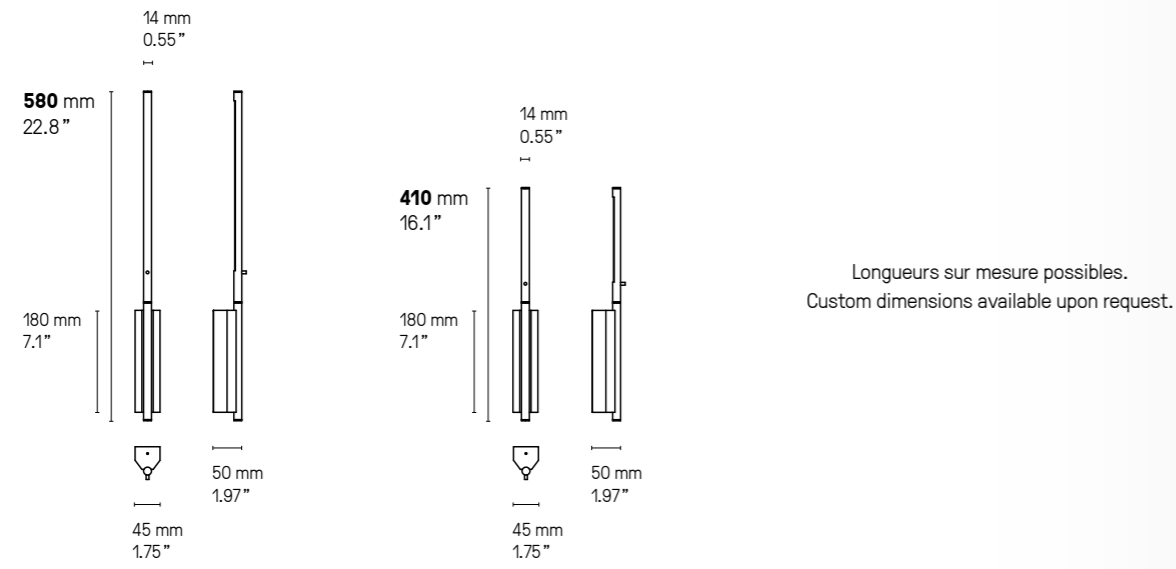

Longueurs sur mesure possibles.  
Custom dimensions available upon request.

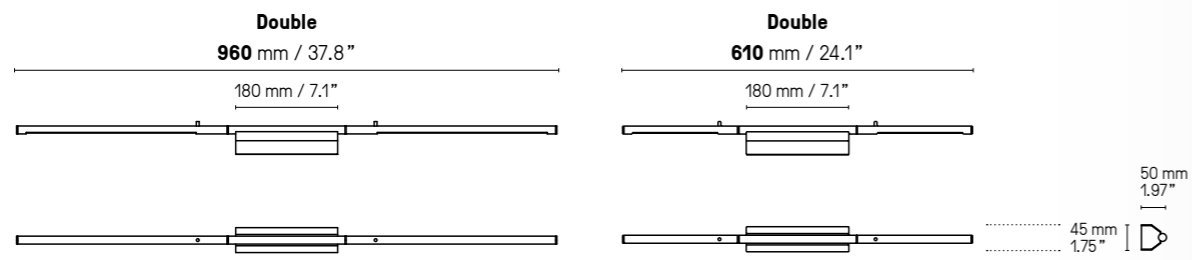
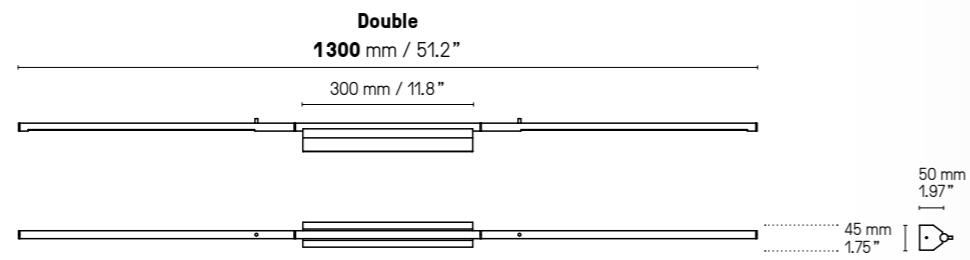

IP Link Double 960 PG



IP Link 410 SB



# IP METROP



## Finitions Finishes ①+②

Détails page 222

● Laiton satiné <b>SB</b> Satin brass	● Graphite satiné <b>SG</b> Satin graphite	● Nickel satiné <b>SN</b> Satin nickel	● Cuivre satiné <b>SC</b> Satin copper
● Laiton poli <b>PB</b> Polished brass	● Graphite poli <b>PG</b> Polished graphite	● Nickel poli <b>PN</b> Polished nickel	● Cuivre poli <b>PC</b> Polished copper

## Matériaux Material

Laiton massif Solid Brass	Diffuseur polycarbonate satiné Satin Polycarbonate diffuser	Ruban Led sans points visibles Led strip without visible dots
------------------------------	--	--

## Source Lamping

<b>IP Metrop 325</b>	LED intégrée Integrated LED	300 lm 300 lm	3000° K 3000° K	Alimentation 24 V intégrée Int. power supply 24 V included	IP44 Non variable en standard IP44 Standard version not dim.
<b>IP Metrop 525</b>	LED intégrée Integrated LED	500 lm 500 lm	3000° K 3000° K	Alimentation 24 V intégrée Int. power supply 24 V included	IP44 Non variable en standard IP44 Standard version not dim.
<b>IP Metrop 780</b>	LED intégrée Integrated LED	750 lm 750 lm	3000° K 3000° K	Alimentation 24 V intégrée Int. power supply 24 V included	IP44 Non variable en standard IP44 Standard version not dim.

## Norme Standard

IP44	Classe II
IP44	Class II

## Designer

Émilie Cathelineau

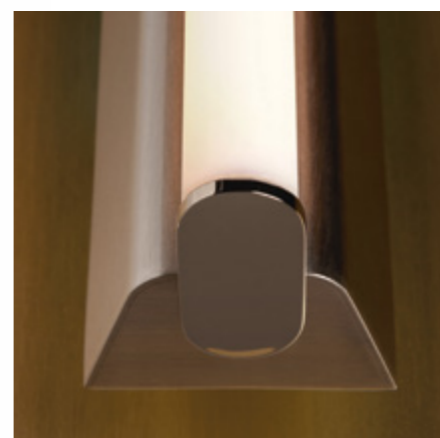

IP Metrop SG/PG



IP Metrop SB/SG

**IP Metrop**

325 mm  
12.8"

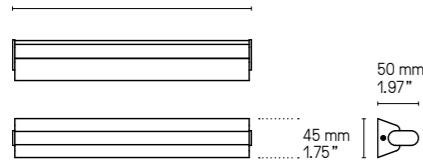

525 mm  
20.7"

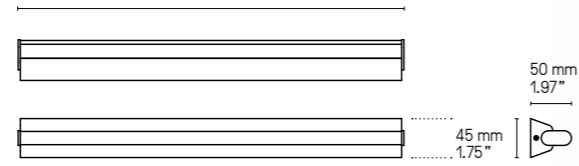

780 mm  
30.7"

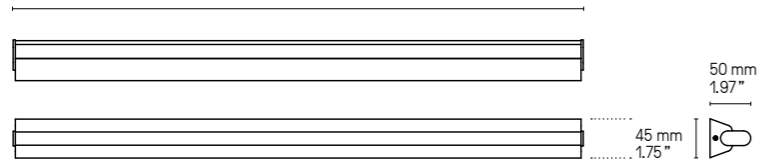

Longueurs sur mesure possibles.  
Custom dimensions available upon request.



IP Metrop 325 PB



IP Metrop 325 SG

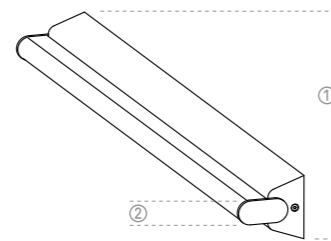

IP Metrop 325 SN/SG



IP Metrop 325 PN



IP Metrop 325 PC

**US Version  
fitted plate to cover outlet power box**

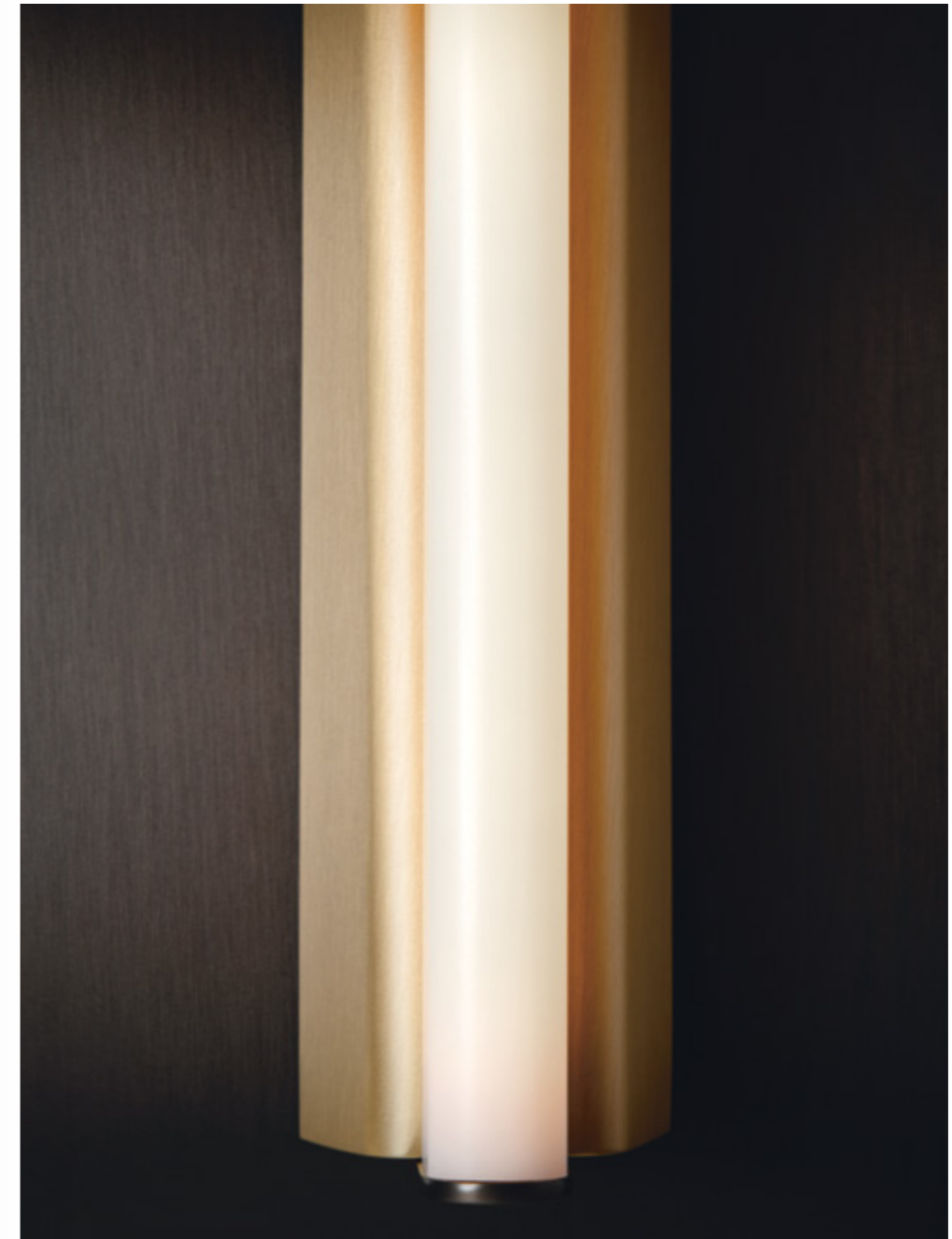
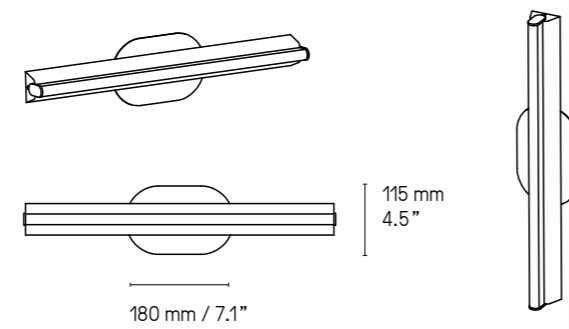

IP Metrop SB/SG



# IP STORM



## Finitions Finishes

Détails page 222

● Laiton satiné <b>SB</b> Satin brass	● Graphite satiné <b>SG</b> Satin graphite	● Nickel satiné <b>SN</b> Satin nickel	● Cuivre satiné <b>SC</b> Satin copper
● Laiton poli <b>PB</b> Polished brass	● Graphite poli <b>PG</b> Polished graphite	● Nickel poli <b>PN</b> Polished nickel	● Cuivre poli <b>PC</b> Polished copper

## Matériaux Material

Laiton massif Solid Brass	Diffuseur polycarbonate blanc White Polycarbonate diffuser
------------------------------	---

## Source Lamping

LED 420 lm 3000°K	Alimentation 24V intégrée Int. power supply 24V included	IP44 Non variable en standard IP44 Standard version not dimmable
-------------------	---	---

## Norme Standard

IP44	Classe II
IP44	Class II

## Designer

Émilie Cathelineau

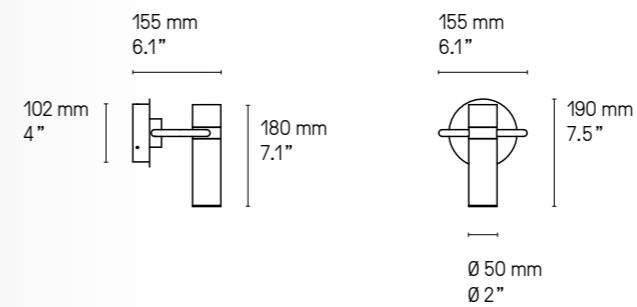

IP Storm SB

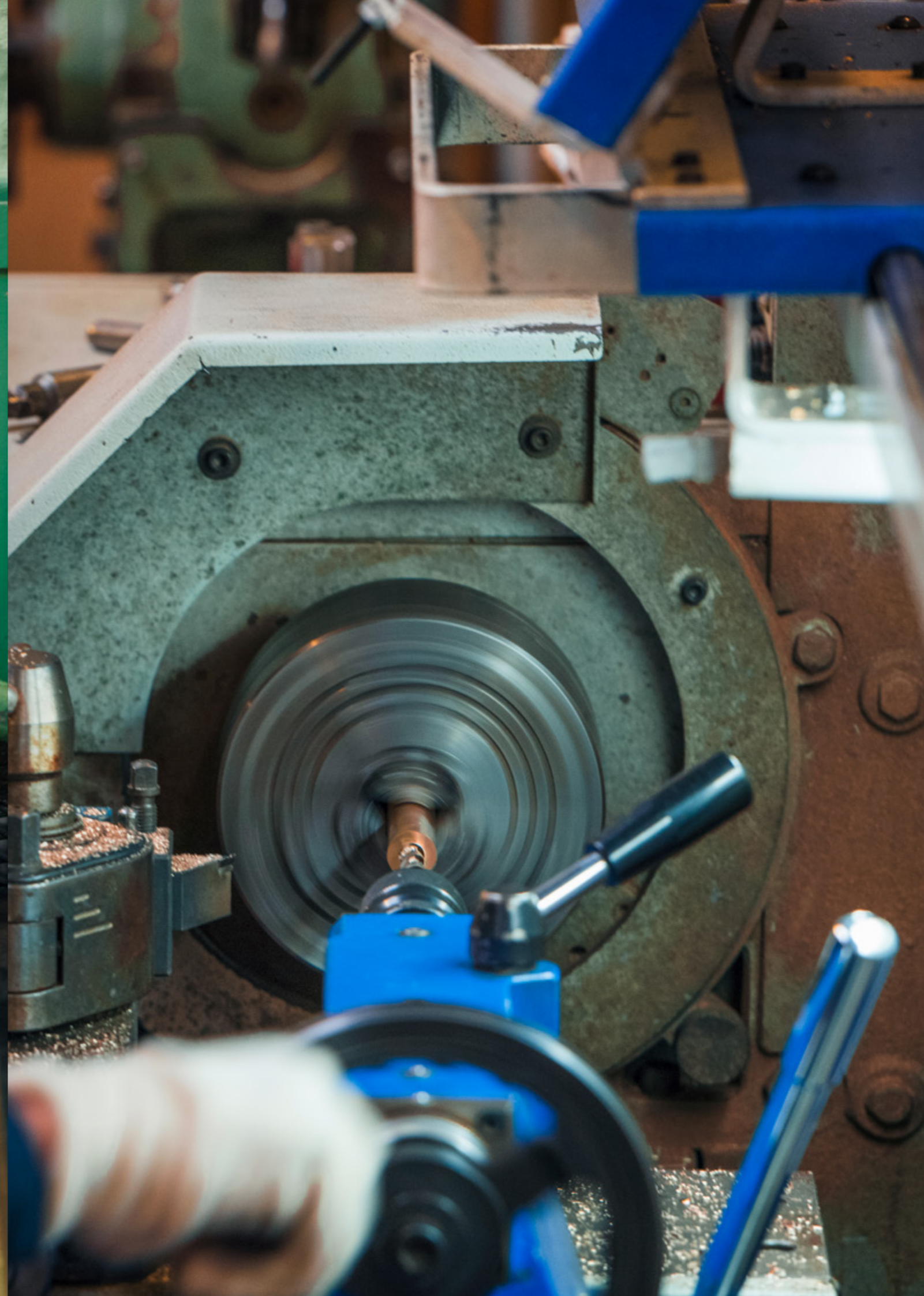







NUANCIER - FINISH OPTIONS



LAITON - BRASS

- |                                    |   |                                     |                                     |
|------------------------------------|---|-------------------------------------|-------------------------------------|
| ① Laiton satiné<br>SB Satin brass  | ② Graphite satiné<br>SG Satin graphite  | ③ Nickel satiné<br>SN Satin nickel  | ④ Cuivre satiné<br>SC Satin copper  |
| ⑤ Laiton poli<br>PB Polished brass | ⑥ Graphite poli<br>PG Polished graphite | ⑦ Nickel poli<br>PN Polished nickel | ⑧ Cuivre poli<br>PC Polished copper |

ABAT-JOURS - LAMPSHADES

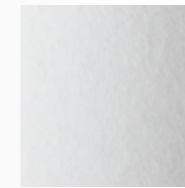

Drop Paper® 100



Drop Paper® 101



Drop Paper® 103

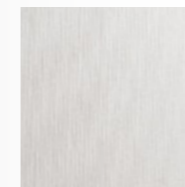

Chinette blanche  
White chinette

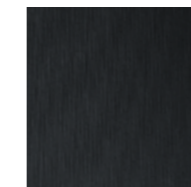

Chinette noire  
Black chinette

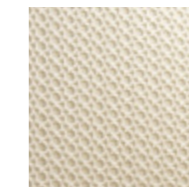

Duke  
Duke

VERRERIE - GLASS



Opale  
Opal

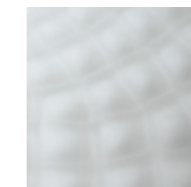

Opale et écaille  
Opal and patterned



Claire et écaille  
Clear and patterned

CÂBLES - CABLES

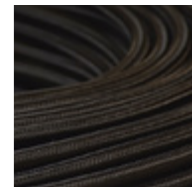

Tissu noir  
Black textile

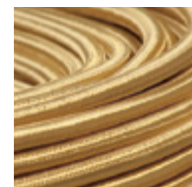

Tissu or  
Gold textile

**Charte graphique & direction artistique**  
**Brand identity & art direction**  
POOL

**Réalisation, suivi de fabrication**  
**Layout, print process supervision**  
deuxpointdeux

**Impression – Printing**  
ALLAIS

#### Images

##### Portraits

Garnier Studios (É. Cathelineau), Stephanie Füssenich (P. Deltour),  
Yannick Labrousse (POOL), droits réservés/all rights reserved (H. Langlais),  
Nicolas Delaroche (S. Willenz)

##### Atelier, détails et groupe – Workshop, details and staff

Yannick Labrousse (p.2-13, 16, 43, 56-57, 120, 190, 195,  
197, 200, 203, 213, 216-221)

##### Photos & 3D d'ambiances – Lifestyle photos & 3Ds

Garnier Studios, except:

3mille for Kelly Boukobza – villa Saint-Tropez (p.20)  
Agathe Tissier for Agence Felicita & Studio Vertbois (p.44, 103, 129)  
Alexander Volodin & Ivan Erofeev for Arch(e)type – Supplier GK Concept (p.121)  
Andres Orozco for Junzi Kitchen (p.141)  
AR visual (p.96, 192, 196, 198, 202, 204, 210, 214)  
Ariane Hera for for Lelievre Paris (p.45)  
Beppe Brancato for Elena Caponi – Pianca (p.36)  
Bureau Gimbert Comy architecture & design (p.47)  
CGI Furniture (p.28, 35, 107, 109, 111, 123, 130, 134, 166)  
Charlotte Taylor x Hannes – 'The Conran Loft' (p.52)  
Claire Illi for DH Liberty – Hampstead Manor (p.160)  
Francis Amiard for Stéphanie Coutas architecte d'intérieur (p.25)  
Frédéric Namur Architecte d'intérieur (p.165)  
Frenchie Cristogatin for agence Jean-Christophe Peyrieux; stylist: Céline Hassen (p.115)  
Iqosa Interior and Architecture Design est. 2014 (p.141, 142)  
Klaas Verdrü for Mayelle architecture d'intérieur (p.138, 146)  
Leatzia Bazzoni for Marie's Corner (p.27)  
Match Architects (p.82)  
Maud Lorton for Mamir Birling – Le Répertoire (p.124)  
Max Zambelli for Flou Mobilier; stylist: Elena Caponi Studio (p.184)  
Moem Studio – Hotel Sofia-Barcelona (p.174)  
Philippe Charlot (p.94-95, 179)  
Pro Design St-Petersburg (p.206, 209)  
Raffles Europejski Warsaw (p.156)  
Rainer Schär for Iria Degen – Hotel Märthof Basel (p.61)  
Stephan Julliard for Studio Lally & Berger – Hôtel Le Meurice à Paris (p.49)  
Volume ABC – Marriott Riviera Cap d'Ail (p.23)  
Yannick Labrousse for POOL – project ROF01, Paris (p.40-41, 51, 55)

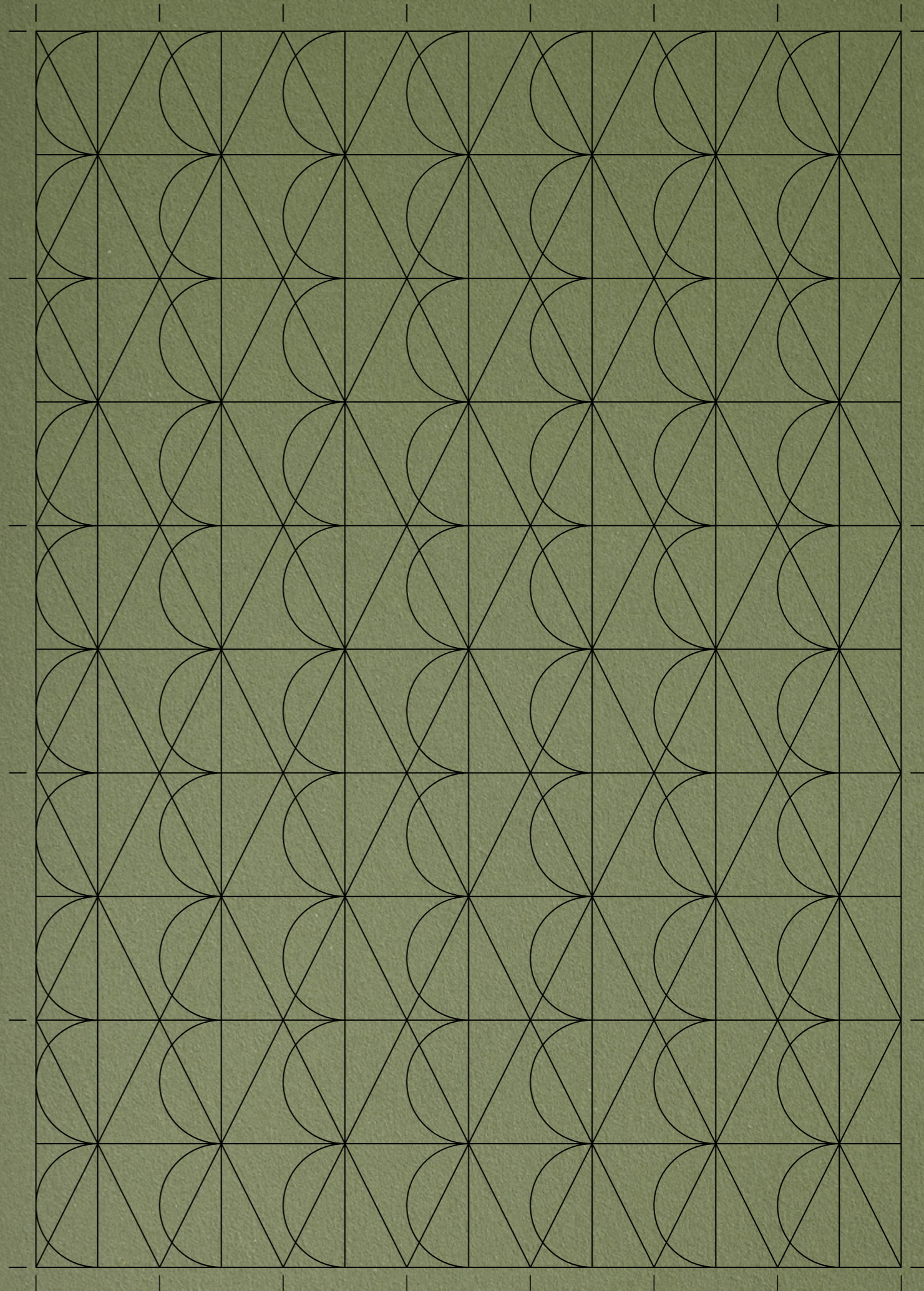

**CVL LUMINAIRES**

79 ROUTE DE LA CHEVALLERIE - 49770 LONGUENÉE-EN-ANJOU - FRANCE

TEL.: +33 (0) 2 41 32 67 54

EMAIL: [CONTACT@CVL-LUMINAIRES.FR](mailto:CONTACT@CVL-LUMINAIRES.FR)

**[WWW.CVL-LUMINAIRES.FR](http://WWW.CVL-LUMINAIRES.FR)**